

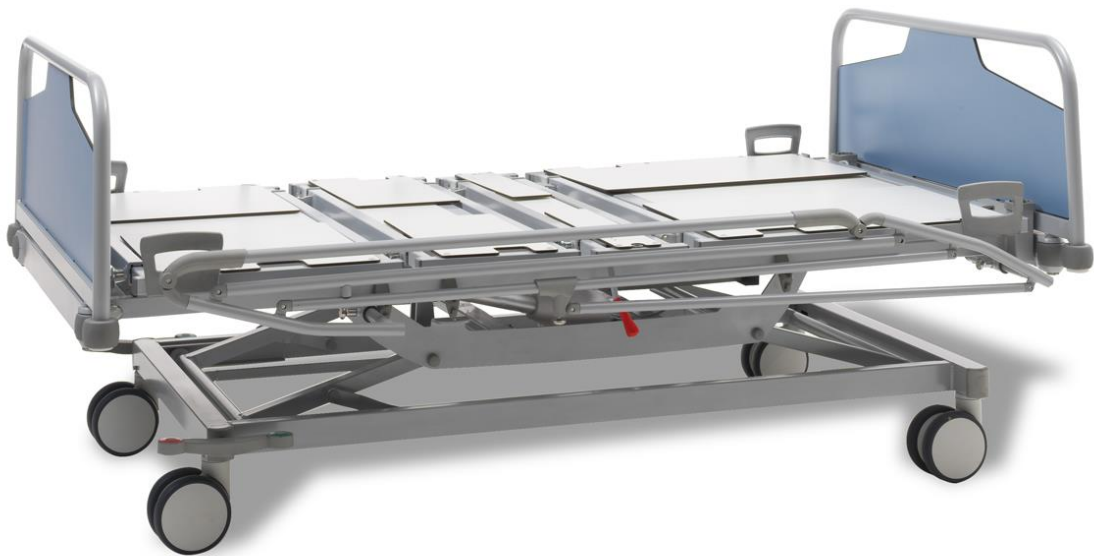

# Operating instructions and Technical manual **Olympia Bariatric**



Version: E 30/01/2017

---

IMPORTANT: RETAIN FOR FUTURE REFERENCE: READ CAREFULLY

# ACTIVATION: SUMMARY

## Olympia Bariatric



Manipulation		Hand switch	Hand switch HD	Mini-nurse box ACC	Nurse box ACO
BACKREST					
KNEEREST					
RELAX POSITION					
HIGH/LOW					
SLEEPING POSITION					
Not active when a function has been locked.					
REVERSE-TREND					
Emergency operations					
TREND.					
CPR					
Irrespective of any blocked functions.					
Lock/Unlock					
Nightlight under the bed on/off					

The available bed functionality is in line with the chosen and ordered configuration.

# Olympia Bariatric

## Quick release

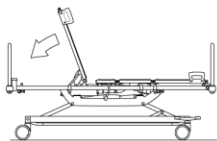

## Lever

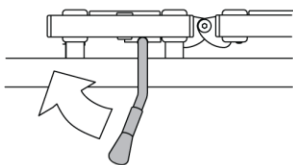

## Bed extension

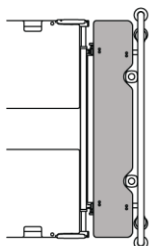

1. lift the footrest
2. pull out both pull knobs
3. pull out the bed extension
4. lock the buttons
5. place the removable foot extension

## Mattress platform widening



1. pull out both pull knobs of the sideguard
2. position the side rail and release the knobs
3. make sure the sideguard is locked
4. pull out the pull knobs of the mattress platform sections
5. position the telescopic sections and release the knobs
6. put the filling mattresses on both sides of the main mattress

## Central brake mechanism

1 directional castor, fixed

4 castors unbraked

4 castors braked

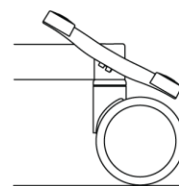
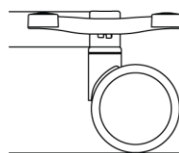
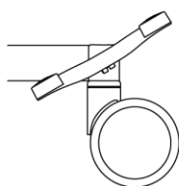

The available bed functionality is in line with the chosen and ordered configuration.

# PREFACE

Dear user,

Haelvoet would like to thank you for the confidence you have put in our company by opting for a Haelvoet product. You have chosen a high-end product resulting from our inexhaustible experience in the development and production of hospital beds. Our continuous pursuit of improvement and optimisation aims at increasing our customer satisfaction even more. All our products are fully checked before they leave our company. If you face a problem, however, please do not hesitate to contact us.

This manual has been written to make you familiar with the installation, the electric and mechanical aspects, and the maintenance of this Haelvoet product. Therefore, we strongly advise you to go through this document before using or servicing the product. Please do not hesitate to ask for extra manuals at Haelvoet NV in case this may seem necessary. We kindly request you to make sure that all users and maintenance technicians have the necessary information at their disposal and have access to it at all times.

The purpose of this manual is to offer you a clear and transparent overview of the functional and technological aspects of the bed. Consequently, Haelvoet NV cannot be held liable for any damage or injuries that result from incorrect product usage, incorrect bed interventions or any possible unclear descriptions in this document. Since Haelvoet NV continually aims at making technological progress, Haelvoet reserves the right to modify the product as well as this manual, and all this without prior notice.

Nothing from this edition may be multiplied and/or made public in any form or manner, either mechanically or electronically, without prior written consent of Haelvoet NV.

# TABLE OF CONTENTS

<b>ACTIVATION: SUMMARY</b> .....	<b>2</b>
<b>PREFACE</b> .....	<b>4</b>
<b>TABLE OF CONTENTS</b> .....	<b>5</b>
<b>LIST OF FIGURES</b> .....	<b>8</b>
<b>I. SAFETY INSTRUCTIONS</b> .....	<b>10</b>
1.1 General instructions.....	10
1.2 Moving sections.....	13
1.3 Sideguards .....	13
1.4 Bed / foot extension.....	14
1.5 Preventive maintenance .....	14
1.6 Mains cable .....	14
1.7 Battery .....	15
1.8 Spare parts and options .....	15
1.9 Alarm signals.....	15
1.10 Applied parts.....	16
<b>II. OPERATING INSTRUCTIONS</b> .....	<b>17</b>
2.1 Electric functions .....	17
2.1.1 Electric function possibilities .....	18
2.1.2 Extra nursing functionalities on the hand switch HD with magnet key (optional) .....	21
2.1.4 Battery.....	22
2.1.5 Illuminated hand switch (option) .....	23
2.1.6 Nightlight under the bed (option) .....	23
2.1.7 Reset Procedure.....	23
2.2 Mechanical functions .....	25
2.2.1 CPR: manual .....	25
2.2.2 Head and foot panel .....	25
2.2.3 Mattress platform .....	26
2.2.4 Central brake .....	26
2.2.5 Moving the bed .....	27
2.2.6 Telescopic mattress platform widening .....	28
2.2.7 Telescopic bed extension .....	30
2.2.8 Drawer for the nurse box (option) .....	31
<b>III. POSSIBLE OPTIONS</b> .....	<b>33</b>

3.1 Sideguards .....	33
3.2 Lifting pole .....	35
3.3 IV rod .....	36
3.4 Flexible hand switch holder .....	36
3.5 Traction frame .....	37
3.6 Patient restraint straps.....	37
3.7 Accessory hooks .....	37
3.8 Equipotential connection .....	37
<b>IV. CLEANING AND DISINFECTION OF THE BED .....</b>	<b>39</b>
4.1 General information .....	39
4.2 Degree of protection of the bed: IPX4 .....	39
4.2.1 Cleaning.....	39
4.2.2 Disinfection .....	40
<b>TECHNICAL MANUAL .....</b>	<b>41</b>
<b>V. GENERAL TECHNICAL DESCRIPTION.....</b>	<b>42</b>
<b>VI. ELECTRIC TECHNICAL DATA .....</b>	<b>45</b>
6.1 Control box .....	45
6.2 Hand switch .....	45
6.3 Hand switch HD.....	45
6.4 Control panel .....	45
6.5 Battery .....	45
6.6 Backrest actuator with quick release.....	46
6.7 Knee rest actuator .....	46
6.8 High-low actuators.....	47
6.9 Specifications off the CB 20 control box.....	47
6.10 Ambient conditions for the actuators .....	48
6.11 Precautions for cable connections .....	48
<b>VII. MECHANICAL TECHNICAL DATA .....</b>	<b>50</b>
<b>VIII. TECHNICAL DATA CASTORS.....</b>	<b>50</b>
<b>IX. STORAGE OF THE BED.....</b>	<b>51</b>
<b>X. PREVENTIVE AND CURATIVE MAINTENANCE .....</b>	<b>52</b>

10.1 Safety responsibility.....	52
10.2 Spare parts .....	53
10.3 Used fastening methods.....	53
10.4 Replacement of a high/low actuator .....	54
10.5 Replacement of a mattress platform actuator .....	54
10.6 Readjustment of the CPR lever .....	55
10.7 Adjusting the speed of the quick release/CPR lever .....	55
10.8 Battery .....	56
10.9 Replacement of the mains cable .....	57
10.10 Replacement of a control box.....	58
<b>XI. POSSIBLE PROBLEMS.....</b>	<b>59</b>
<b>XII. ACCESSORIES .....</b>	<b>60</b>
<b>XIII. GUARANTEE .....</b>	<b>60</b>
<b>XIV. RESIDUAL WASTE AND THE ENVIRONMENT .....</b>	<b>61</b>
<b>XV. SYMBOLS .....</b>	<b>63</b>
<b>XVI. CONFORMITY.....</b>	<b>64</b>
16.1 Explanation CE-label and identification-label.....	64
16.2 Symbols .....	65
<b>APPENDIX 1: EC-DECLARATION .....</b>	<b>67</b>
<b>APPENDIX 2: CHECKLIST MAINTENANCE.....</b>	<b>68</b>
<b>APPENDIX 3: EMC-TABLES .....</b>	<b>70</b>
<b>APPENDIX 4: TRAINING CERTIFICATE.....</b>	<b>74</b>

# LIST OF FIGURES

Figure 1.1: Physical description of an adult patient .....	10
Figure 1.2: Applied parts .....	16
Figure 2.1: Hand switch .....	17
Figure 2.2: Hand switch HD with magnet key (optional) .....	17
Figure 2.3: Nurse box ACO (optional) .....	17
Figure 2.4: Mini nurse box ACC (standard) .....	17
Figure 2.5: Depiction of an electric High-low adjustment.....	19
Figure 2.6: Extra functionalities on hand switch HD with magnet key.....	21
Figure 2.7: Blocking of the electric functions on the mini nurse box and nurse box.....	22
Figure 2.8: Indication LED on the battery .....	23
Figure 2.9: Nightlight under the bed .....	23
Figure 2.10: Reset Procedure Control box .....	24
Figure 2.11: CPR lever .....	25
Figure 2.12: Removable head and foot panel.....	25
Figure 2.13: How to lock the head and foot panel .....	26
Figure 2.14: 4-section mattress platform .....	26
Figure 2.15: The 4 castors braked.....	26
Figure 2.16: 4 unbraked castors .....	27
Figure 2.17: One directional castor.....	27
Figure 2.18: Suspension hooks for the mains cable .....	28
Figure 2.19: How to adjust the width of the sideguards .....	29
Figure 2.20: How to adjust the mattress platform width.....	29
Figure 2.21: Adding the extra filling mattresses.....	30
Figure 2.22: Access to the bed extension.....	30
Figure 2.23: How to extend the bed.....	30
Figure 2.24: Extension of the foot end (option).....	31
Figure 2.25: Opening of the drawer .....	31
Figure 2.26: Installation of the nurse on the foot panel.....	32
Figure 2.27: Linen holder.....	32
Figure 3.1: Sideguards Atmosphere Bariatric: dimensions .....	33
Figure 3.2: Manipulation of the sideguards type Atmosphere.....	34
Figure 3.3: Lifting pole .....	35
Figure 3.4: Adjustment of an IV rod .....	36
Figure 3.5: Installation of the flexible hand switch holder .....	36
Figure 3.6: Accessory hooks .....	37
Figure 3.7: Equipotential connection at a standard head panel.....	38
Figure 5.1: Mattress platform dimensions Olympia Bariatric bed.....	43
Figure 5.2: Dimensions of the Olympia Bariatric bed.....	43
Figure 5.3: Most important manipulation data of the Olympia Bariatric bed .....	44
Figure 6.1: Circuit diagram Olympia Bariatric .....	49



Figure 10.1: Axle and axle retaining ring ..... 53

Figure 10.2: Cable clamp ..... 54

Figure 10.3: Quick release ..... 55

Figure 10.4: Adjusting the quick release mechanism/ CPR lever mechanism ..... 55

Figure 10.5: Release of the strain relief type 1 ..... 57

Figure 10.6: Release of the strain relief type 2 ..... 57

Figure 10.7: Replacement of a mains cable in the control box ..... 58

Figure 10.8: Fixing of the strain relief, both types ..... 58

Figure 10.9: How to replace the control box CB20 ..... 58

# I. SAFETY INSTRUCTIONS

## 1.1 General instructions



We strongly advise you again to read the entire manual, so that the instructions for an optimal use as well as those for a preventive and curative bed maintenance are carefully followed. The bed should be installed, maintained and used in accordance with this manual. Please inform all readers about the possible risks that can be run when not reading or following this manual.

The manufacturer, installer, importer or distributor of this product can only be held liable and stand surety for the basic safety, reliability and required qualities of the product if:

- decently trained technicians perform assembly tasks (e.g. assembly of accessories), adjustments, modifications, repairs and/or maintenance work.
- the bed is connected to electric installations that meet the requirements of the bed.
- the bed is used and maintained in accordance with the instructions in this manual and in a way that is considered a normal use of a hospital bed.
- the user, patient and technician have become acquainted with this manual and/or have received a good training of a qualified person.

By doing so, the risks for both the nursing staff and the patient are reduced considerably, whereas the product life of the bed is increased. At all times, the reader of this manual should be aware of the fact that this is an electric bed, and that the nursing staff and patient should be informed of the risks involved. Furthermore, all bed functions should be checked annually. Haelvoet NV even recommends that the bed is checked every six months, so that the safety of the patient is guaranteed even more.

This hospital bed is intended and made to treat, guard, alleviate or compensate diseases, injuries or handicaps of an **adult who is at least 146 cm tall and has a BMI of at least 30**.

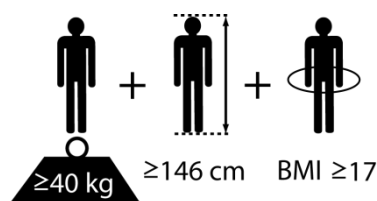

**Figure 1.1: Physical description of an adult patient**

The BMI is the ratio between weight (in kg) / length x length (in m). When this is higher than 30, a person is considered bariatric.

The Olympia Bariatric bed can be used in environments 1, 2, 3 and 5, as defined in IEC 60601-2-52:2009. It may not be used in environment 4, because of the electric protection class I.

The maximum safe working load of the bed is 500 kg. If used in environments 1 and 2, the maximum safe patient weight is 435 kg. If used in environments 3 and 5, the maximum safe patient weight is 465 kg.

Appropriate precautions have to be taken to treat small patients. Small children have to be put in a cot or child's bed. Furthermore, it is very dangerous for children to operate the bed or to use it as a toy.

Please inform every user about the possible risks when the bed is used incorrectly, especially when the actuators and the sideguards have to be used.

Before you start using the bed, please make sure that the bed functions properly. That is why you have to check the following elements *before* you use it:

- Remove all packing material and recycle it environment-friendly.
- Please check if the bed and all its parts have been delivered in accordance with the delivery note.
- Please check if the bed has not been damaged during transport and delivery.
- In case huge temperature differences have to be overcome: let the bed adapt itself to the room temperature for 24 hours before using it and connecting it to the net.
- Make sure that the brakes of the bed have been activated.
- Read the entire manual.
- Clean the bed, as described in chapter IV of this manual.
- Please check if the power cable and the bed are compatible with the mains current of the room.
- Please check if the power cable, actuator cables and hand switch cable have not been damaged. Make sure that they have been installed in such a way that they cannot be damaged.
- Make sure that no obstacles hinder the free movement of the bed.
- Equip the bed with its mattress, sheets and/or blankets, and make sure that they cannot obstruct the handles, the CPR lever and sideguards.
- Check the bed functionality by means of the check list. (see appendix)
- Connect the bed only to a correctly installed socket in the vicinity of the bed.



The Olympia Bariatric bed always has to be connected to a net with a properly functioning earthing system.



Only use electric appliances that function perfectly in the vicinity of the bed. Make sure that these appliances are never connected by means of a multi-socket under the bed (risk of electrocution and fire because of the fluids). You should avoid using extension cords and multi-sockets.

This bed complies with the 93/42/EEC directive about medical devices and is categorized as a class I product. Keep in mind that every technical product, whether it is mechanical or electric, can be dangerous when it is used incorrectly. You should give priority to the interest and safety of the patient, visitor and manipulator at all times. Make sure that all users have access to this manual.

It is the responsibility of the distributor to inform the customer about the bed's functionality, maintenance and disinfection. The customer has to contact the distributor in case of uncertainties or insufficient user information. He also has to address himself to the distributor if he wants additional training.

Persons (playing children in particular) or obstacles may never be under the bed. Please make sure that all other equipment is put in safe conditions, before the bed is lowered, raised or removed. Take also care of the patient's safety during any bed manipulation. No bed function may be activated if there are obstacles of any kind in the vicinity of the bed.

Please make sure that the patient is put in the bed in the correct position. His head should be placed at the head end, whereas his feet should be at the bed's foot end.

Load the bed and its actuators only to the extent as described in the technical file. Always contact the technical service when the bed makes strange noises or movements.

Always activate the brakes when the bed does not have to be moved. Please ascertain yourself of this by trying to move the hospital bed afterwards. By doing so, you minimize the risk of having unwanted accidents when the patient tries to leave the bed. In order to increase the patient's safety, it is advisable to put the bed always in its lowest position, especially when the patient is sleeping. Make also sure that the bed has been put in its lowest position before you leave the patient alone. Furthermore, the bed has to be put on a flat, horizontal surface.

Never remove the bed when the castors are braked. You should also make sure that certain bed accessories (lifting pole, IV rod...) do not hinder a safe and fluent passage through doors and the like. Please be careful when moving the bed and avoid collisions, especially with other persons.



Never take place on a mattress platform without a mattress. To guarantee the safety, the bed has to be equipped with a mattress that complies with the following specifications:

Mattress dimensions: 90 cm x 195 cm

Mattress thickness: **20 cm**

Minimum stiffness of the foam: 2,8 kPa in accordance with ISO 3386 (CLD/40%)

Fire retardant material

In case visco-elastic foam is used, a supportive layer of minimum 7 cm with a minimum stiffness of 3,6 kPa in accordance with ISO 3386 (CLD/40%) has to be used.

The Trendelenburg-position may only be activated by persons that have received a medical training. Please switch off all electric functions that may not be used by the patient.

When you use additional or peripheral equipment, you have to make sure that everything has been installed correctly and that everything functions properly. Please avoid using loose cables or wires and do not use multi-sockets. Contact your supplier or Haelvoet NV if you have any questions about peripheral equipment.

Devices that create strong electromagnetic fields and that may possibly influence the control of the bed are not permitted in the direct vicinity of the bed. Take also into account that the bed creates electromagnetic fields and may possibly influence the (measure) equipment used near the bed. However the bed is approved according to EN 60601-1-2, residual risks are possible.

The bed may not be used when there is a risk of explosion, or in the vicinity of inflammable, volatile anaesthetic gases.

When you think that there is some damage or that the bed does not function properly, you have to disconnect the bed immediately. You also have to indicate clearly on the bed that it is OUT OF USE. Contact the person who is in charge of the beds as soon as possible.

The bed may only be used when the following ambient conditions are present:

- Temperature: between 5°C and 40°C.
- Humidity of 20% to 90% at 30°C without condensation.
- Atmospheric pressure between 700 and 1060 hPa.

## 1.2 Moving sections



Make sure that you can't get stuck between or in the moving sections, even if these sections are not activated.

All sections should be able to move freely (do not install the bed near a windowsill or other obstacles). Make sure that the mains cables of peripheral equipment (patient lift, compressors, reading lamp,...) can never get stuck or damaged during a bed manipulation.

## 1.3 Sideguards



**If the bed is moved with the patient still in it, the sideguards must always be put in their highest position. The same instruction applies when the patient is sleeping, or for all other circumstances, during which the nursing staff deems this necessary. Always check if the sideguards are locked properly.**

**Always put the different mattress platform sections and mattress platform inclination in the lowest horizontal position. Of course, this can only be done when the medical condition of the patient is not jeopardized. The aim of this action is to prevent that the patient gets stuck or can fall out of the bed. After all, this bed position guarantees the best patient protection.**

**The sideguards have to be widened in the same way as the mattress platform. Please make sure that no gap is created because the sideguards are wider than the mattress platform.**

**It should, however, be stressed that the sideguards do not constitute an obstacle to stop people that wish to leave the bed wilfully. If the medical staff thinks this will happen, they should take the necessary precautions.**

Never remove the bed by pulling at the sideguards. Only use undamaged, and technically perfect sideguards, of which the distances between the siderails comply with the statutory standards.

Only use original Haelvoet sideguards, since these have been tested in accordance with the official standards. Regularly check if the sideguards still function properly.

Only use fitting, fire-retardant mattresses that have the correct dimensions and a sufficient hardness. Never use mattresses that are too thick. In order to protect the patient sufficiently, there always has to be a distance of 22 cm between the non-compressed mattress and the upper side of the sideguards. Mattresses that are too thick cause an efficiency loss of the sideguards. If the required distance is not obtained, you have to opt for another mattress or extra aids, so that this safe height is always guaranteed.

Always check if the sideguards and the distances between the siderails guarantee enough protection for the patient. Do not forget to keep the patient's figure in mind. It may be necessary to use additional protection equipment – such as a protective cover – for thinner and more fragile patients. Such accessories can be the only alternative to reduce the patient's risk from falling through the sideguards or getting stuck. Always pay attention to the physical and mental state of the patient and always take the necessary precautions.



**If you don't keep the above-mentioned guidelines in mind, a patient can run the risk of getting stuck between the siderails. If the distances between the siderails are too big, the patient can also fall out of the bed. These distances can be caused by damage, incorrect usage or faulty sideguards. It is also possible that this has happened because the sideguards have been locked incorrectly.**

## 1.4 Bed / foot extension

The bed is standard equipped with a bed extension. If the bed extension is used, the gap created between the footrest and the foot panel has to be filled. This can be done by means of the removable foot extension, so that there is no gap larger than Ø 11 cm between the mattress platform, panel and the sideguards.

## 1.5 Preventive maintenance



All bed functions should be checked at least annually. For this purpose we refer to chapter X of this manual.

The bed may only be repaired by a qualified technician in case of a malfunction or defect. Disconnect the bed immediately and clearly indicate on the bed that it is "OUT OF USE". Contact the person who is in charge of the bed as soon as possible. Repairs by unqualified persons may cause severe damage or injuries.

## 1.6 Mains cable



When installing or removing the bed, please ascertain yourself of the fact that the bed does not stand on the connecting cable or that the cable is not jammed between the moving sections. Never ride with the bed over the connecting cable or pull at it.

Please check the mains cable at regular times. Pay attention to any damage (e.g. compressed, a kink, open wires, etc.). Make sure that the cable is not jammed, and never ride with the bed over the mains cable. Never remove the bed without first disconnecting the mains cable. Also ascertain yourself of the fact that the strain relief sufficiently clamps the mains cable.

Pull the plug out of the socket when you want to clean the bed or perform an intervention on it.

## 1.7 Battery

Never try to bore the battery. Never throw it in a fire. Please return the replaced batteries to the manufacturer or dealer for recycling.

A fully discharged battery is defective. It is therefore advised to always connect the bed to the net, and only to use the battery as a back-up in case of emergencies.

If a bed has not been used and/or connected to the net for a long period, it is recommended to remove the batteries. By doing so, you avoid problems with leaking batteries.

## 1.8 Spare parts and options



Only use spare parts or options that have been approved by Haelvoet NV.

Haelvoet NV cannot be held liable for any damage or injuries resulting from modifications to the bed, and/or the use of non-original spare parts or options without the knowledge and written consent of the manufacturer.

## 1.9 Alarm signals



The Olympia Bariatric bed is equipped with several alarm signals, including the 'Medium level battery'.

If the capacity of the battery is going below a safe level to guarantee the electric functions of the bed, the following warning signal will sound at the moment when one of these functions is activated.

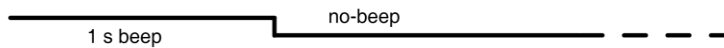

Connect the bed to the net as soon as this warning signal sounds. We would like to refer to section 6.8 in this manual for more information about other alarm signals.

# 1.10 Applied parts

1	Bedpanels
2	Sideguards
3	Mattress platform parts

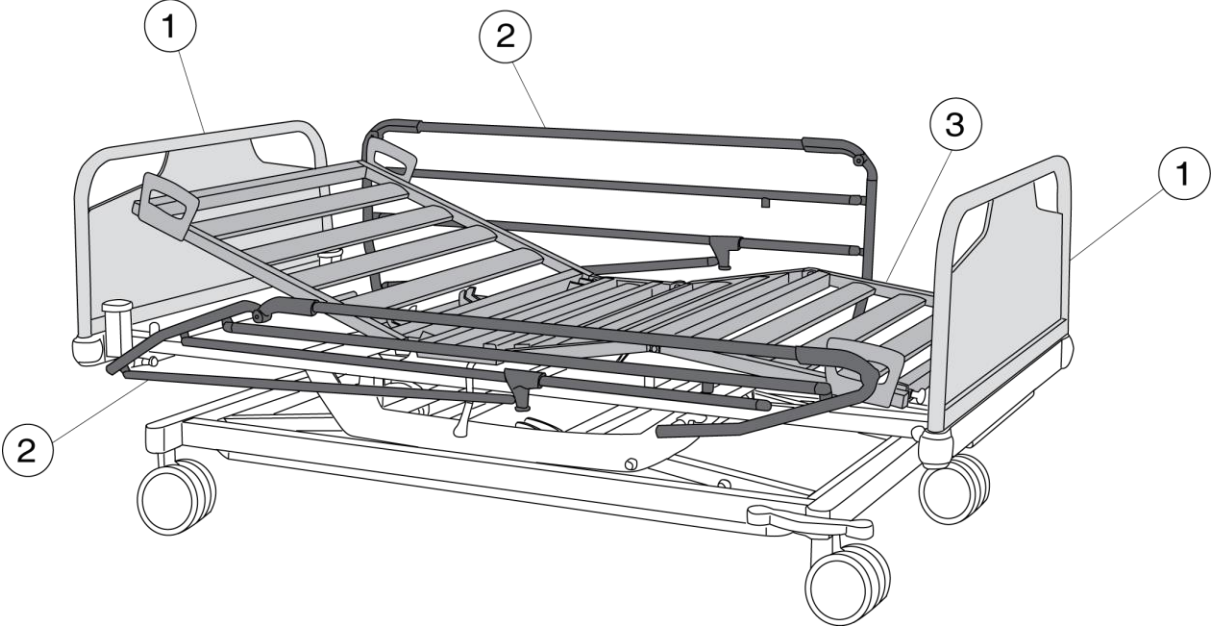

Figure 1.2: Applied parts



## II. OPERATING INSTRUCTIONS

### 2.1 Electric functions



Please always explain the electric functions to the patient, and inform him about the possible risks while using the bed. Users may only operate the bed when they have sufficient knowledge or experience with the bed. Patients with impaired physical or mental capabilities may only manipulate the bed when there is sufficient supervision.

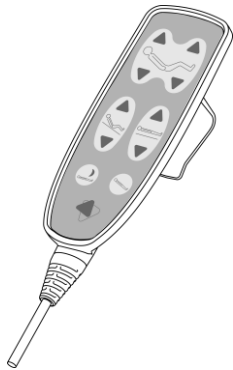

Figure 2.1: Hand switch

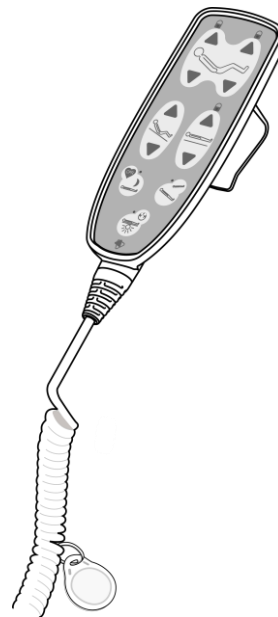

Figure 2.2: Hand switch HD with magnet key (optional)

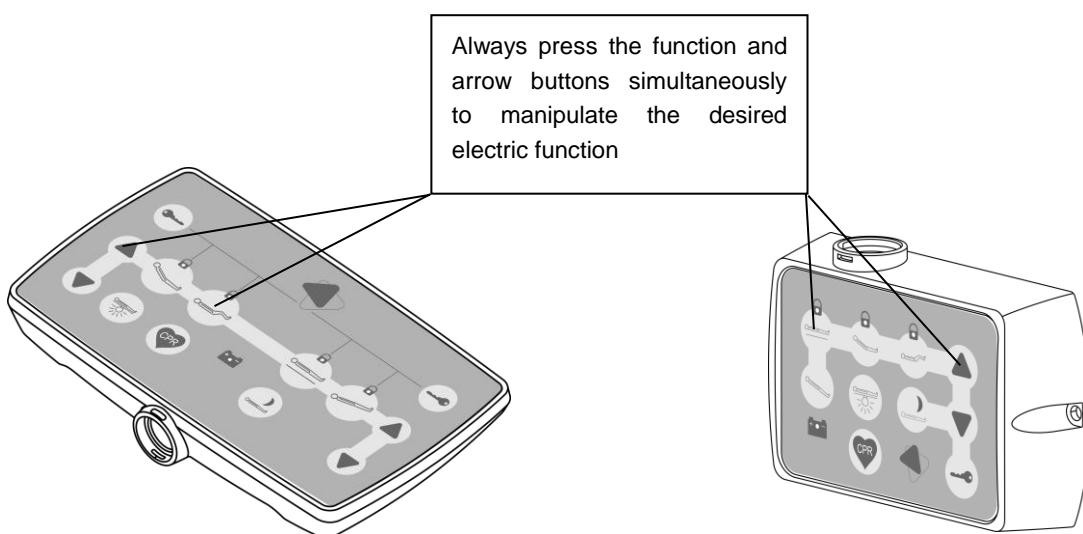

Figure 2.3: Nurse box ACO (optional)

Figure 2.4: Mini nurse box ACC (standard)

Remark: The nurse box or mini nurse box is at the foot end of the bed.

All electric control buttons are *Momentary Touch buttons*. The number of bed functions depends on the ordered bed configuration.

The hand switch can optionally be put in a flexible holder, which results in an optimal accessibility of the hand switch for the patient (see 3.4)



**Make sure that the patient and especially children cannot reach the hand switch, or block the electric bed functions in order to guarantee the patient's safety. This applies for the following cases:**

- **When children are near the bed without supervision**
- **If a bed manipulation can be dangerous for the patient**
- **If the sideguards are put in their highest position. In this case, the patient can run the risk of getting stuck in the sideguards during a bed manipulation**
- **If the patient is not capable of operating the bed safely, or when he can put himself in danger by operating the bed**
- **If additional equipment or accessories can be dangerous or harm the patient.**

Only qualified and trained personnel are allowed to operate the bed in the above-mentioned cases.

Please keep the 10% rule in mind. Never operate the bed continuously longer than 2 minutes. When you have used the bed continuously for 2 minutes, you have to make sure that the bed is not activated for at least 18 minutes.

Despite the fact that the electric bed equipment complies with all regulatory obligations, there is still a chance that there is a interference on another device during a bed manipulation. If this is the case, you have to put the other equipment further away from the bed and connect it to another net. If it is possible, you have to connect the bed and its equipment with the equipotential connection.

### 2.1.1 Electric function possibilities



**Make sure that no part of the body is situated between the moving parts.**

a. Backrest adjustment: electric



This function can be activated by means of the hand switch or nurse box.

Maximum angle of inclination = 70°. The angle between the backrest and knee rest is always at least 90°.

b. Knee rest adjustment: electric



This function can be activated by means of the hand switch or nurse box.

Maximum angle of inclination = 34°. The angle between the backrest and knee rest is always at least 90°.

c. High-low adjustment: electric



This function can be activated by means of the hand switch or nurse box.

To maximize the life span of the bed, the high-low adjustment is limited to a lifting capacity of 500 kg. (=75% of the motor power)

The mattress platform can be adjusted in height, even when it is put in a Trendelenburg or Reverse-Trendelenburg position. When the mattress platform is activated upwards or downwards, the mattress platform will stop as soon as the front or back of the mattress platform reaches its highest or lowest position. After having pushed the button a second time, the mattress platform will be put in a horizontal position.

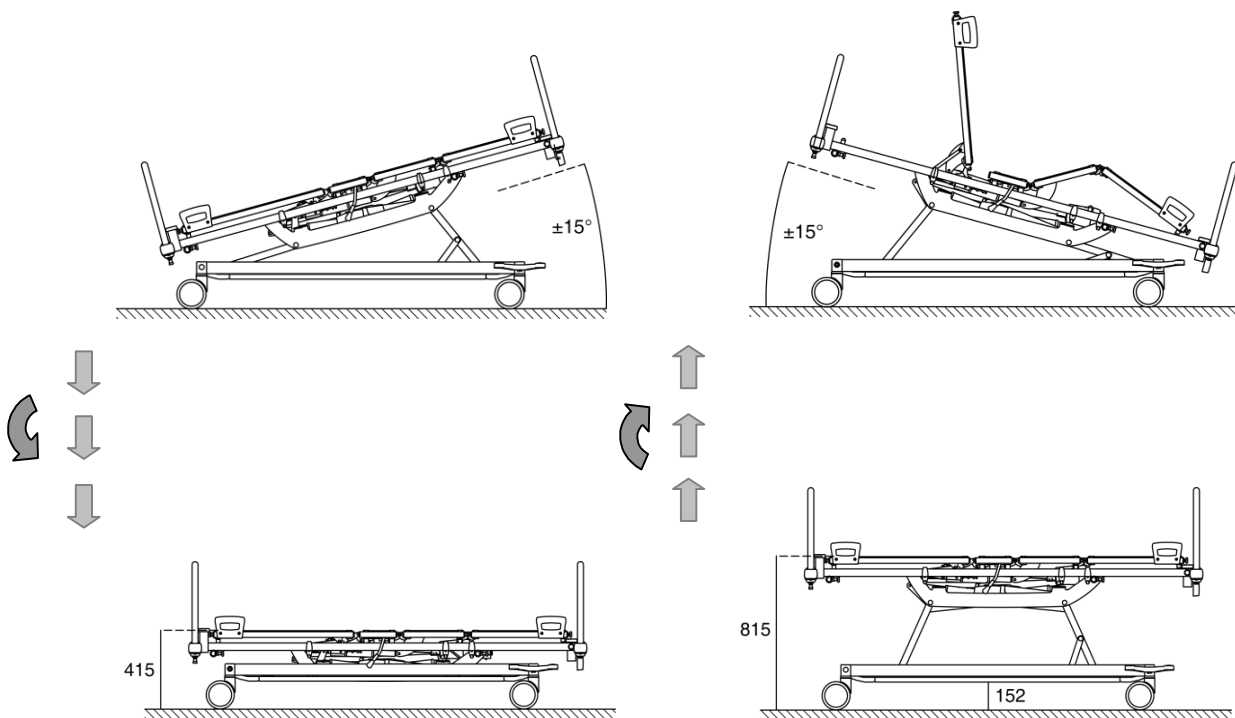

Figure 2.5: Depiction of an electric High-low adjustment

Keep in mind that the mattress platform can be put in a horizontal position by means of the hand switch, provided that the high-low function is not blocked by the nurse box or mini nurse box.



**Please make sure that nobody is under the mattress platform before you activate this manipulation! Make sure that there are no objects on or around the carriage that can block a height variation.**

**Put the bed in its highest/lowest position on a regular basis, so that it can reset itself.**

**Because of the high lifting capacity, the bed and/or its accessories (e.g. a lifting pole) can possibly damage the surroundings during a bed manipulation.**

d. Trendelenburg/Reverse-Trendelenburg: electric



The Reverse-Trendelenburg position can be activated by means of the hand switch or the nurse box, whereas the Trendelenburg position can only be activated by means of the nurse box or mini nurse box. The Trendelenburg position may only be activated by persons who have had a medical training. These persons should take the medical condition of the patient into consideration.



**Make sure that nobody is under the bed before activating this function!**

e. Relax/seat position: electric

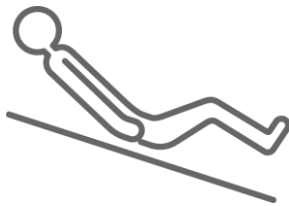

This function is only available on the hand switch. When activating this function, the backrest and knee rest are inclined simultaneously, whereas the head end is put in its highest position.

f. Sleeping position: electric



This function can also be activated by means of the hand switch, mini nurse box or nurse box. All mattress platform sections are put horizontally, whereas the bed is placed in its lowest position, by pressing one single button.



**Never overload the bed, not even for a short period. In case you have no other option owing to circumstances, please put all mattress platform sections in a horizontal position. Also put the bed in its lowest position.**

## 2.1.2 Extra nursing functionalities on the hand switch HD with magnet key (optional)

With a magnet key  the extra nursing functionalities of the hand switch are activated during 5 seconds.

If during these 5 seconds, no action has been taken, the hand switch turns back to the standard functionalities.

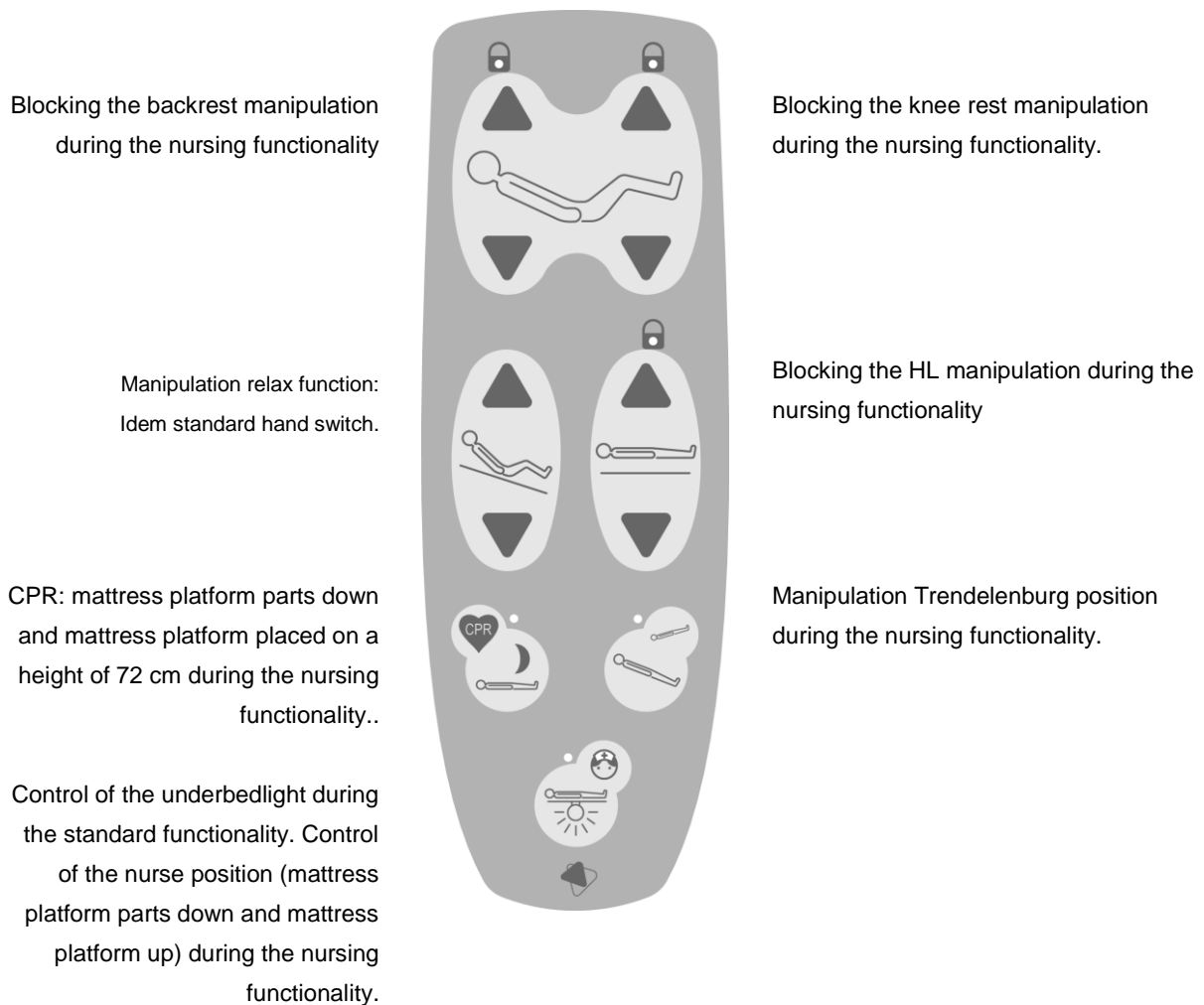

**Figure 2.6: Extra functionalities on hand switch HD with magnet key**

Always put the hand switch outside the reach of the patient, or block the electric functions, if these functions constitute a danger for the patient. This rule also applies for transport, maintenance,...

### 2.1.3 Blocking of the electric functions

The following functions can be switched off by means of the standard mini nurse box or the optional nurse box:

1. backrest adjustment
2. knee rest adjustment
3. high-low adjustment and Trendelenburg – Reverse-Trendelenburg (simultaneously)

To do so, you have to press the function button and block button simultaneously.

A LED indication shows which function is blocked.

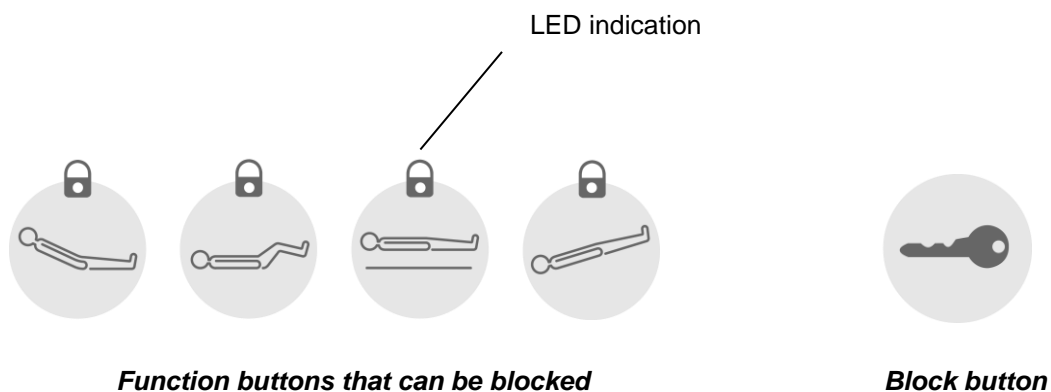

**Figure 2.7: Blocking of the electric functions on the mini nurse box and nurse box.**

These functions cannot be activated by the hand switch, nor by the nurse box after they have been blocked. Always check this block function in case the bed does not want to perform a certain function.

Always put the hand switch outside the reach of the patient, or block the electric functions, if these functions constitute a danger for the patient. This rule also applies for transport, maintenance and the like.

### 2.1.4 Battery

Charge the battery completely (at least 12 hours) before you start using the bed. Always connect the bed to the net, because frequent, high and long discharges can influence the battery's life span negatively.

The battery's average life span, when used correctly, is at least 3 years, depending on how much you use it.

Only use the battery when there is an electricity breakdown or when you transport the patient. An alarm signal warns you when the battery capacity is not sufficient enough anymore during an electric manipulation. If this is the case, you have to connect the bed to the net immediately.

The LED indication on the mini nurse box or nurse box shows when the battery is charging.

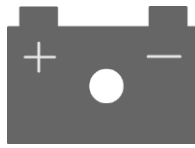

**Figure 2.8: Indication LED on the battery**

### **2.1.5 Illuminated hand switch (option)**

The push buttons on the hand switch are illuminated in light green when activated. This makes it easier for the patient to use the hand switch in a dim room.

### **2.1.6 Nightlight under the bed (option)**

A nightlight is installed under the mattress platform. Thanks to this, the patient can find his way in a dim room, without having to contact the nursing staff or the patients.

The nightlight is activated by pressing the function button on the mini nurse box or nurse box.



**Figure 2.9: Nightlight under the bed**

### **2.1.7 Reset Procedure**

A fault of the control of the bed is visible in following cases:

- The green LEDs on the hand switch flash
- A signal sounds when pressing a function

The control of the bed needs to be reset as described in Fig 2.10

## Reset Procedure

Push both functions on the 2nd row at the same time. An acoustic signal confirms the start of the reset procedure. Keep the buttons pressed till the signal has stopped.

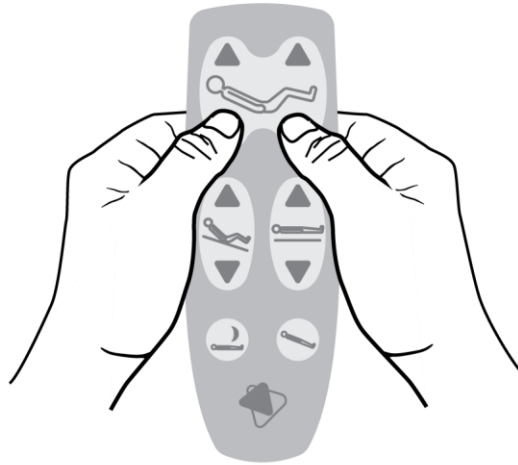

Bring the bed to its highest position to initialize the software.

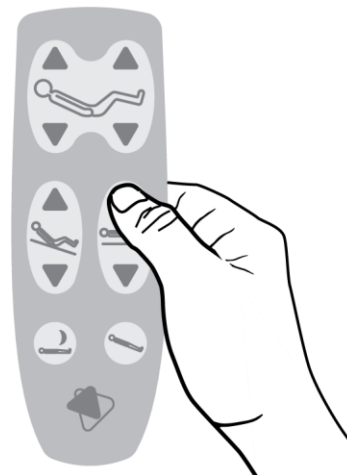

**Figure 2.10: Reset Procedure Control box**



## 2.2 Mechanical functions

### 2.2.1 CPR: manual

A red CPR lever is installed on both sides of the fixed mattress platform section.

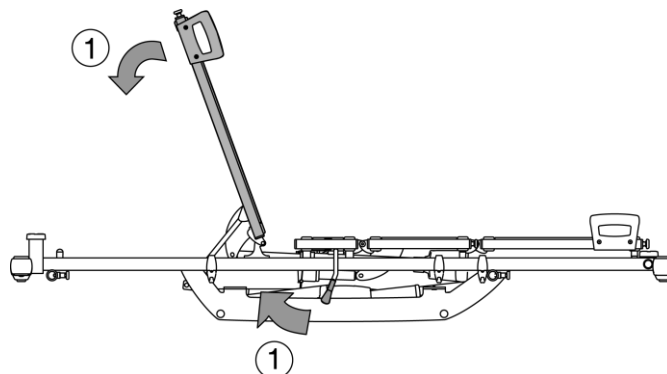

Figure 2.11: CPR lever

The backrest can be manually brought downwards by activating the CPR lever towards the headrest.



**In order to maximize the product life of the actuators and the quick release, it is of the utmost importance that this lever is only used in EMERGENCY SITUATIONS.**

**Make sure that there are no objects that hinder the free movement of the backrest. Please take all necessary measures to prevent that the patient or nurse can get stuck. For this reason, you first always have to put the sideguards in their lowest position.**

### 2.2.2 Head and foot panel

The head and foot panel can be removed and put back very easily without needing any tools. They have to be taken with both hands. The panels are available in three different widths, corresponding with the mattress platform width of the bed: 91, 111, 131 cm (see 2.2.4 mattress platform).

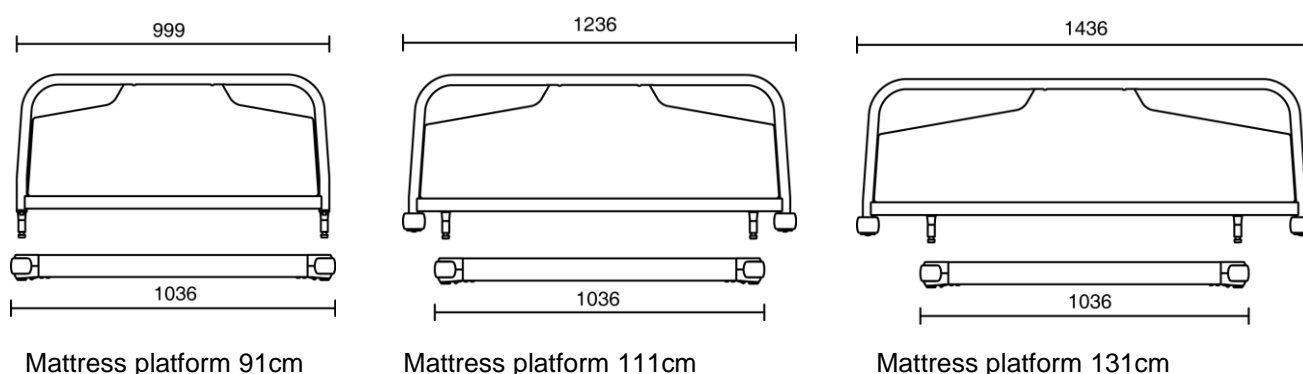
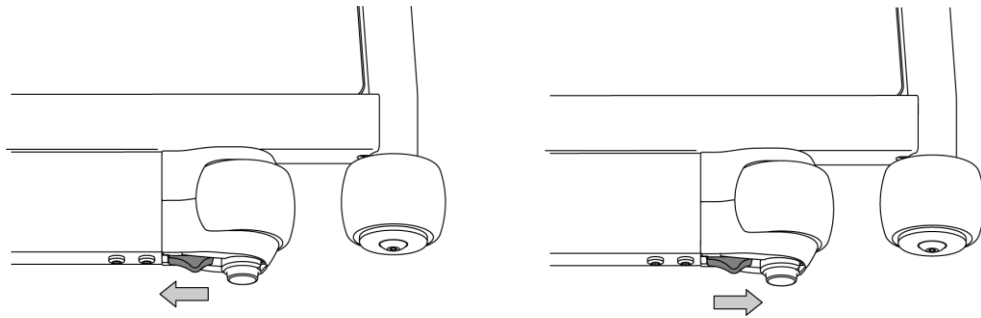

Figure 2.12: Removable head and foot panel



**Always use a panel that corresponds with the set width of the mattress platform.**

The panel is equipped with a lock mechanism, so that it cannot be removed involuntarily.



**Figure 2.13: How to lock the head and foot panel**

### 2.2.3 Mattress platform

The mattress platform of the Olympia Bariatric bed consists of 4 sections. Each section is made of a fixed middle part and telescopic sides. Thanks to this concept, the mattress platform width can be changed into 91, 111 or 131 cm. The mattress platform sections are equipped with solid laminate sections. These sections can be easily cleaned.

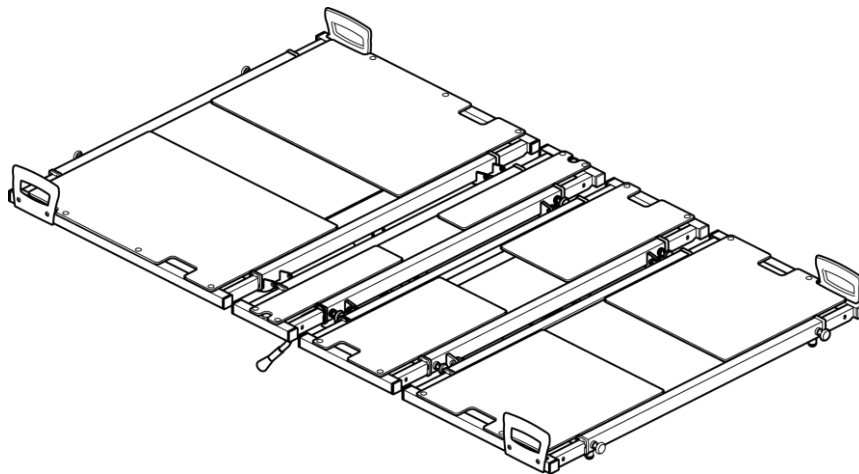
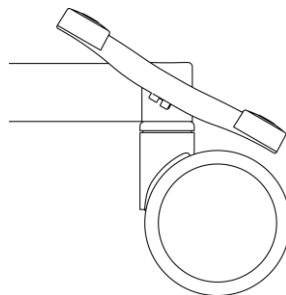

**Figure 2.14: 4-section mattress platform**

### 2.2.4 Central brake

The carriage is equipped with a design brake pedal on both sides of the foot end. This pedal activates all 4 castors simultaneously, and can be set in three positions. The red pedal activates the brake, whereas the green pedal deactivates it.

- The 4 castors braked

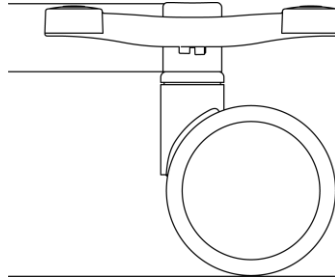

**Figure 2.15: The 4 castors braked**



**Disconnect the bed from the net, and put the mains cable on the suspension hooks. Always put the sideguards in their highest position, and release the brake before moving the bed.**

- 4 unbraked castors: This position makes it possible to move the bed in all possible directions.



**Figure 2.16: 4 unbraked castors**

- Directional castor: This position guarantees that one castor cannot swivel, which makes it easier to move the bed in a straight line.

Always make sure that the directional castor is set in the same position as the other castors. If this is not the case, a stable and straight-lined bed course cannot be guaranteed.

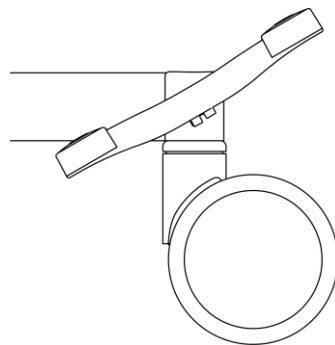

**Figure 2.17: One directional castor**



**Never pull or push at the side of the bed when the directional castor has been activated.**

The castors leave no marks on tiles, carpets, linoleum or laminate floors. Please check if the castors leave marks on parquet floor because of the use of parquet cleaning products.

The castors have been developed to be used on smooth and cleaned floors. The castors can be damaged when you use them on rough, uneven and dirty floors.

## 2.2.5 Moving the bed

The following steps must be followed to remove the bed in a safe and durable way:

- Put the sideguards in their highest position.
- Put the bed in a transport height that suits you.
- Disconnect the plug from the net and hang the mains cable to the suspension hooks at the head end.



Never pull the mains cable, and never remove the bed without disconnecting it from the net.



When the mains cable has not been stored properly during transport, the risk of mains cable damage or electrocution increases substantially. Please make sure that the mains cable is not torn off, squeezed or crushed. Do not ride the bed over the mains cable.

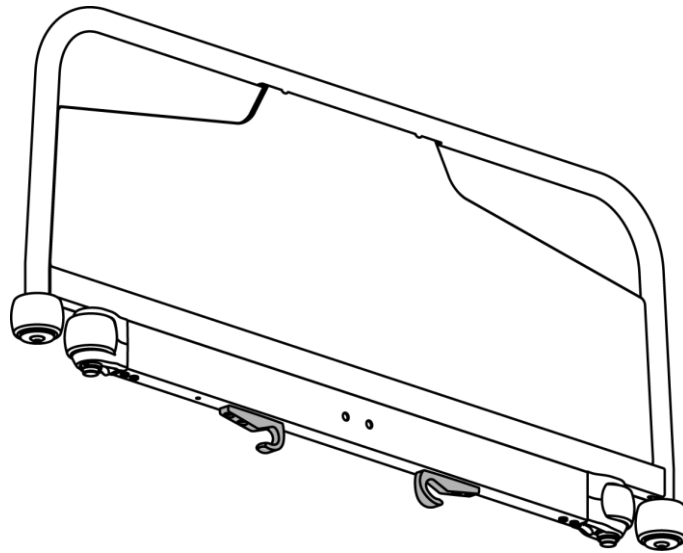

**Figure 2.18: Suspension hooks for the mains cable**

- Take the foot panel with both hands at the push rod.
- Release the central brake and activate, if necessary, the directional castor.
- Make sure that the bed and all its accessories (lifting pole, IV rod,...) can pass through the doors without any problems.
- Please be careful, when moving the bed, not to hit other persons. This because of the high weight.
- Activate the central brake as soon as the bed has been brought to a standstill.

### 2.2.6 Telescopic mattress platform widening

The mattress platform of the Olympia Bariatric bed consists of 4 mattress platform sections. Each section can be telescopically adjusted, which makes the following mattress platform widths possible: 91, 111 or 131 cm.

To obtain the bed width you want, please follow the procedure described hereunder:

- Put the sideguards in their highest position so that you can reach the indexing plungers better.
- First widen the sideguards in the desired position. To narrow these, first reposition the telescopic mattress platform width.

Pull the indexing plungers at the head and foot, while pulling out the sideguards. Release the buttons, and make sure the sideguards have been locked properly. Check this by trying to pull them.

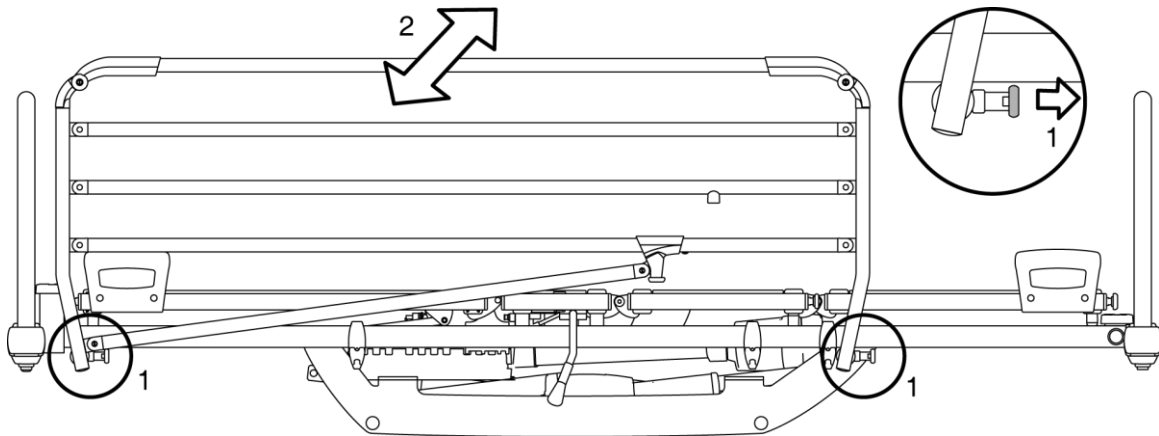

**Figure 2.19: How to adjust the width of the sideguards**

- Widen the mattress platform sections. Do this symmetrically on both sides, so that the lateral bed stability is guaranteed.

There is one block button for each telescopic section. Pull this button while pulling out the section until the desired width has been reached. Release the button and check if the mattress platform has been locked properly by trying to pull the telescopic section.

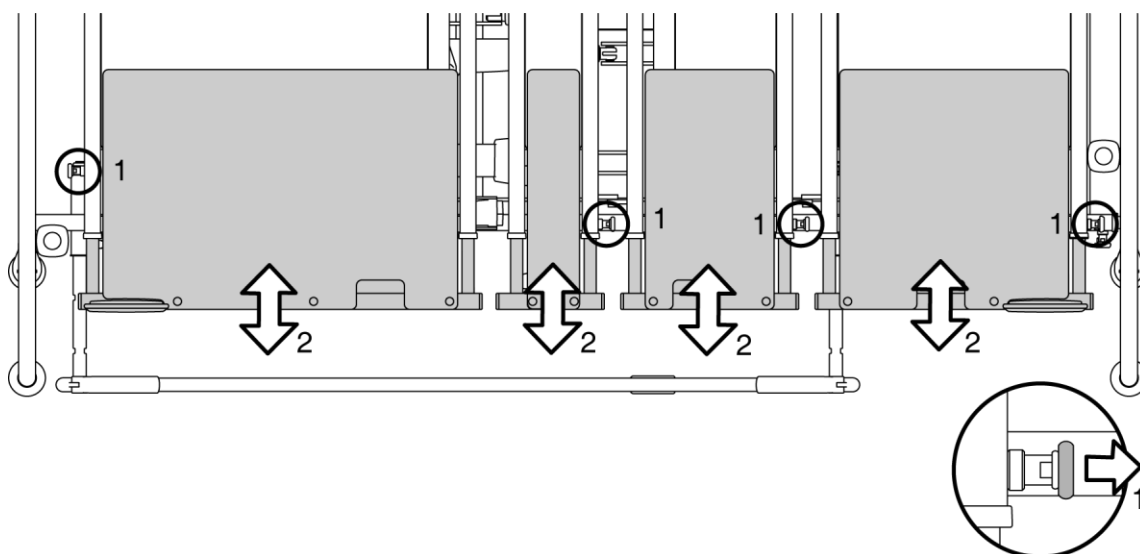

**Figure 2.20: How to adjust the mattress platform width**



**Make sure that the mattress platform has been widened in the same measurements as the sideguards. If this is not the case, the risk of getting stuck increases.**

- Now put the main mattress in a central position on the mattress platform. Put the filling mattresses on both sides of the main mattress.

The longest filling mattress is put on the backrest, the shortest are respectively put on the fixed mattress platform/knee rest and footrest. Make sure that these mattresses are fixed properly by means of the Velcro at the bottom.

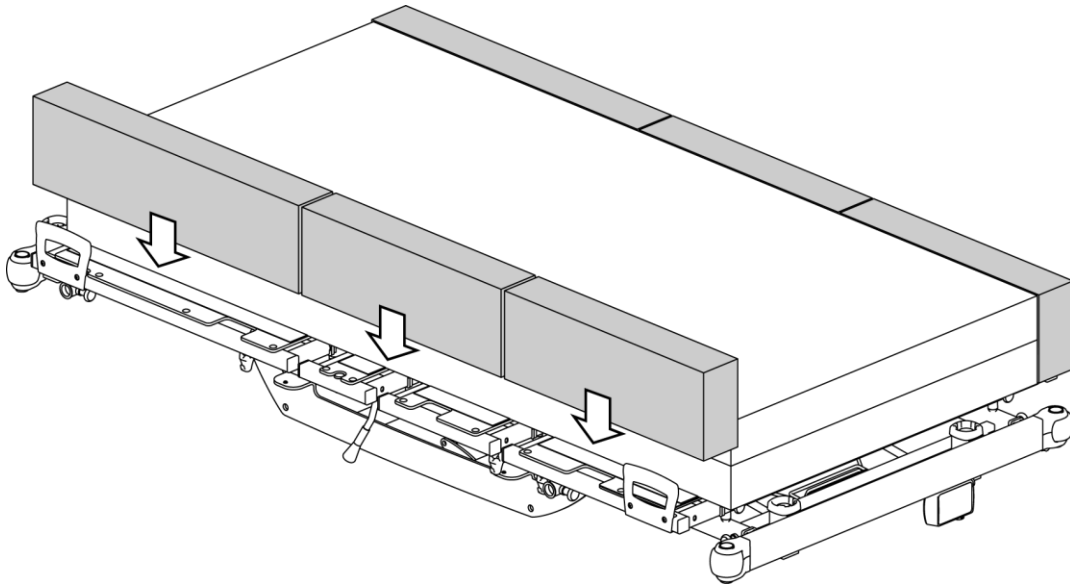

**Figure 2.21: Adding the extra filling mattresses**



**A correct position of the filling mattresses is necessary to reduce the risk of getting stuck.**

### 2.2.7 Telescopic bed extension

The telescopic bed extension is part of a possible bed configuration. This mechanism is installed at the foot end and has to be activated as follows:

- Put the sideguards in their highest position to have a better access to the block buttons.
- Pull the indexing plungers at the exterior of the right and left side beams and rotate them a little.

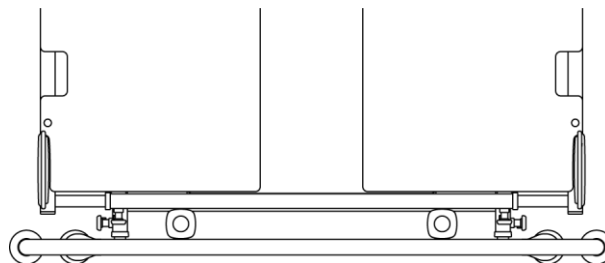

**Figure 2.22: Access to the bed extension**

- Pull the cross beam until the desired extension has been obtained. The bed can be extended to maximum 20 cm. The extension happens in steps of 10 cm.

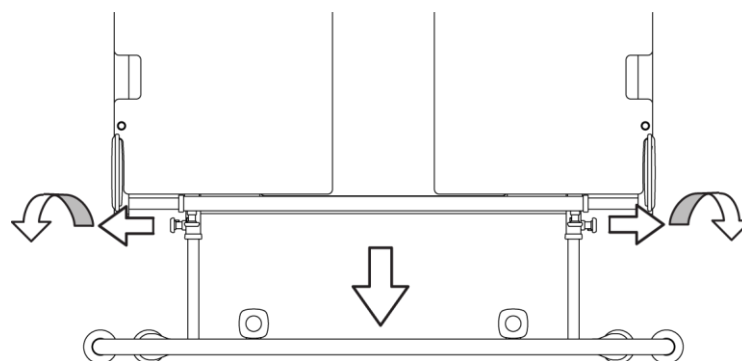

**Figure 2.23: How to extend the bed**

- Put the indexing plungers back in their original position and make sure that they lock the mechanism. Check this by trying to extend or shorten the bed.
- Install the removable mattress platform extension.

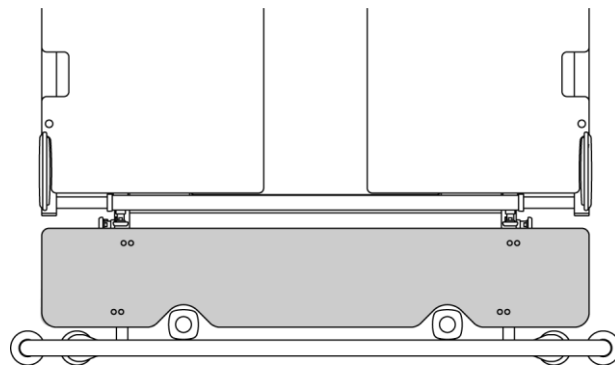

**Figure 2.24: Extension of the foot end (option)**

- Make sure that the mattress reaches the head panel, and put the filling mattress at the foot end.



**Always fill the created gap with a suitable mattress, so that the patient cannot get stuck.**

### 2.2.8 Drawer for the nurse box (option)

If you opt for the optional nurse box instead of the mini nurse box, then the bed will be standard equipped with an extendable drawer/blanket rack.

When this configuration has been chosen, the nurse box is installed under the bed. Thanks to this, it is not only optimally protected during transport, but it also remains outside the reach of visitors and the patient.

When the drawer is opened, the nurse box can be taken out of the drawer and clipped on the foot panel.

Put the spiral cable carefully in the drawer, when installing the nurse box.

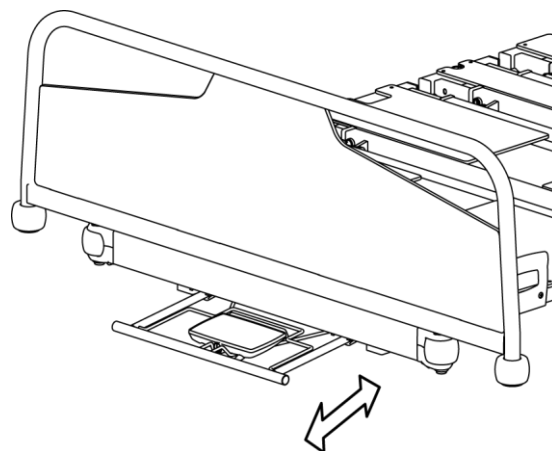

**Figure 2.25: Opening of the drawer**

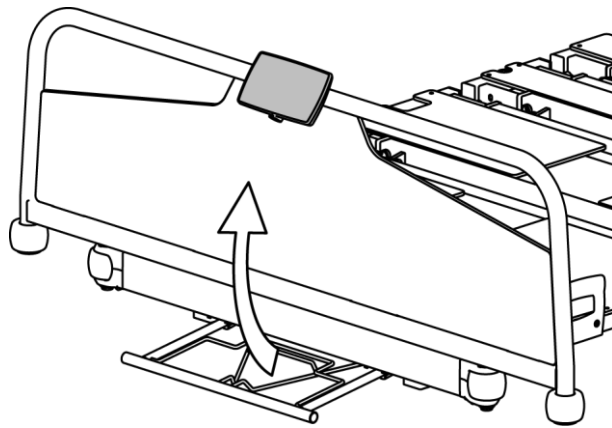
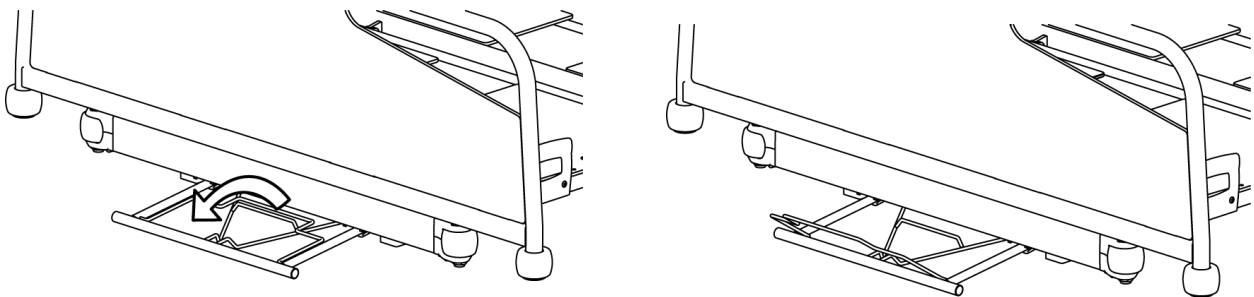

**Figure 2.26: Installation of the nurse on the foot panel**

When the drawer is being opened, you can also tilt over the linen holder , so that the pillow or linen can be laid on it. The maximum load on the drawer is 5 kg.



**Make sure that you lock the drawer properly (on the left and right side) after you have used it.**



**Figure 2.27: Linen holder**



### III. POSSIBLE OPTIONS

The Olympia Bariatric bed can be equipped with:

- Sideguards Atmosphere
- Nurse box ACO + extendible drawer
- Illuminated hand switch
- Nightlight under the bed
- Wall spacer
- Inclination indicator

#### Accessories

<i>IDnr</i>	<i>Description</i>	<i>IDnr</i>	<i>Description</i>
00441	Flexible hand switch holder	05876	Urine bottle holder (horizontal)
10321	Lifting Pole Olympia Bariatric	03799	Writing table
01856	IV hook	05878	Bowl holder
01862	Name card holder	06366	Oxygen bottle holder
01863	Synthetic file holder A4 (horizontal)	09242	Bed pan holder
01864	Synthetic file holder A4 (vertical)	09603	Monitor/device holder
03576	Synthetic file holder A3 (horizontal)	09629	Accessory brace
03272	Traction brace	10771	Removable mattress platform extension
03296	Urine bottle holder (vertical)		

### 3.1 Sideguards



**Please follow all safety instructions of paragraph 1.3 at all times!**

Weight: Set of sideguards: 13.8 kg

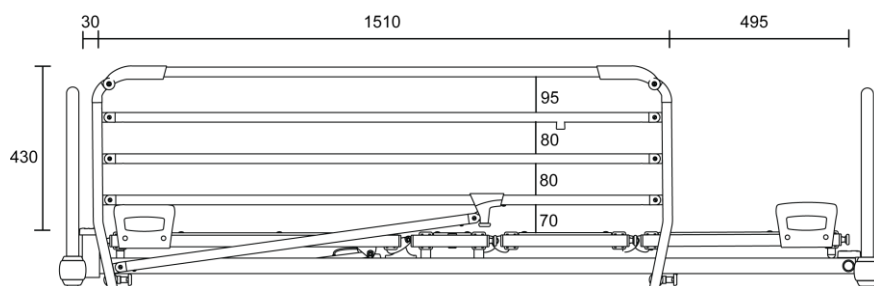

**Figure 3.1: Sideguards Atmosphere Bariatric: dimensions**

These sideguards are attached to the bed frame and form one unity. The undermentioned method has to be followed to lower a sideguard:

- Take the sideguard handle at the head or foot end with one hand
- Pull the pull knob in the middle of the bottom tube with the other hand.
- Move the sideguards towards the foot end.

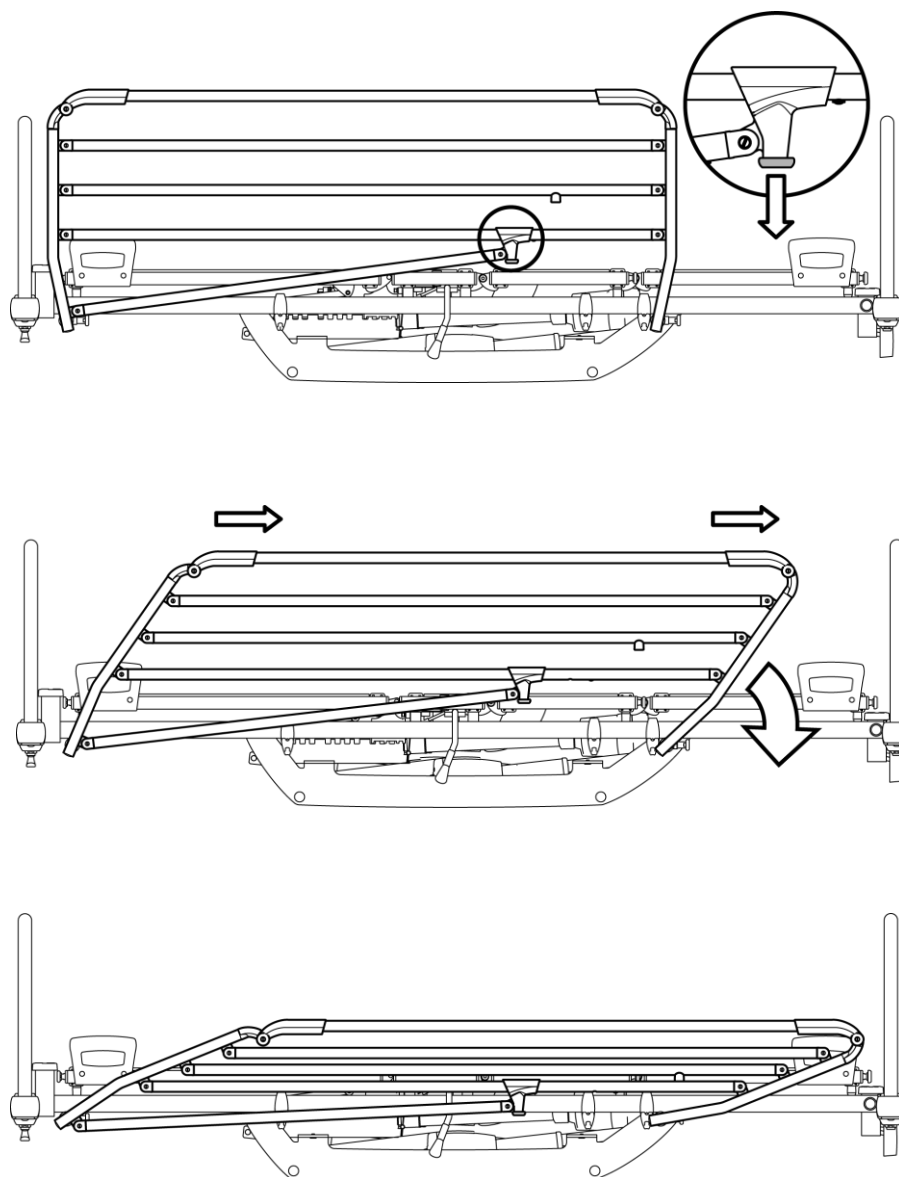

Figure 3.2: Manipulation of the sideguards type Atmosphere



Please always make sure that the sideguards are locked after having raised them. Please make sure that no part of the body or objects can get stuck between the sideguards. Always put the sideguards in their highest position when you intend to leave the patient alone.



The mattress platform should always be put in its lowest and most horizontal position, when the medical condition of the patient allows this (e.g. state of health at that moment or disorientation because of medicines). When taking the patient's condition into account, the medical staff can exceptionally opt for a different lying position of the patient.



Never let the sideguards fall, but support them while lowering them.



Don't forget to keep the preventive maintenance in mind, as described in the technical part of this manual.

## 3.2 Lifting pole

The lifting pole may only be installed in the cases **at the head end**. The lifting pole is not intended to be used as a rehabilitation device!



**Taking a large safety margin into account, the maximum static load is 100 kg.**

It is recommended to check the suspension ribbon on a regular basis. It is also advised to replace the handle preventively every 4 to 5 years.

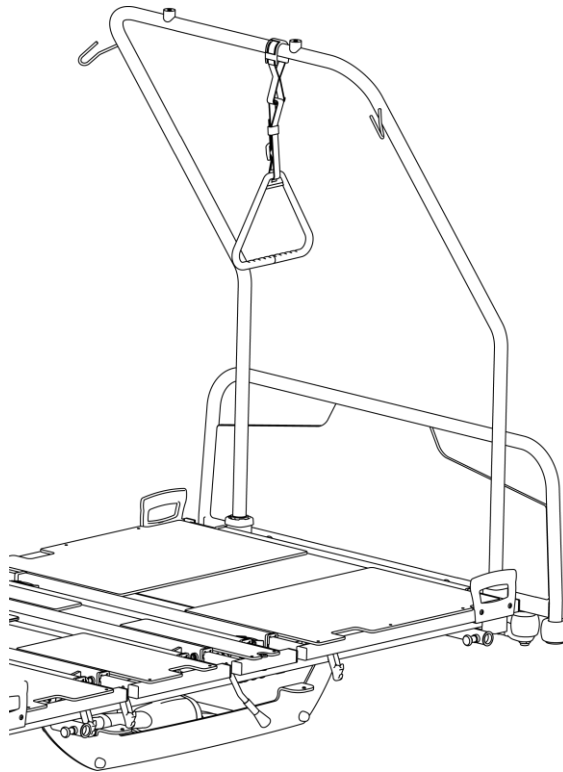

**Figure 3.3: Lifting pole**

Weight : 8.5 kg



**If the bed has been equipped with a lifting pole or an IV rod, it is strongly recommended to pay attention to the zone surrounding the lifting pole and IV rod, especially when you manipulate the bed. By doing so, you prevent that the bed equipment or devices get damaged. Always make sure that the patient cannot get stuck.**

### 3.3 IV rod

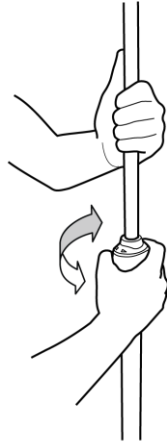
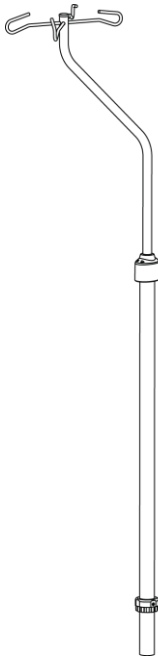

The IV rod can be placed in the synthetic cases of the 2 bed corners at the head end of the bed. The extending part should be held very firmly, before the turn knob is loosened to adjust the height of the IV rod. By doing so, you avoid that the IV rod glides unwantedly into the fixed part!

**Figure 3.4: Adjustment of an IV rod**

Weight of the IV rod: 3 kg

Maximum load on the hook: 2 kg

### 3.4 Flexible hand switch holder

The flexible hand switch holder has to be placed in the provided left or right case near the fixed mattress platform section.

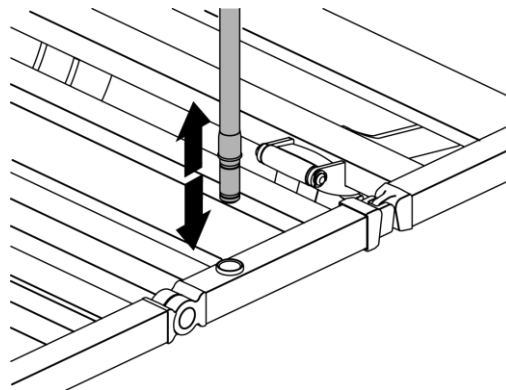

**Figure 3.5: Installation of the flexible hand switch holder**

Weight: 0,5 kg

### 3.5 Traction frame

The traction frame makes it possible to use traction materials on the Olympia Bariatric bed. Two standard brackets were designed for this purpose. Haelvoet NV can optionally always develop brackets in function of the traction material used in the hospital.

Weight: 2.2 kg/piece

### 3.6 Patient restraint straps

The left and right sides of the mattress platform are equipped with several reinforced cut-outs for patient restraint straps.

### 3.7 Accessory hooks

The side beams are equipped with 3 synthetic accessory hooks on both sides of the bed. Several accessories can be optionally bought to attach to/in these synthetic hooks.

maximum load: 10kg per hook

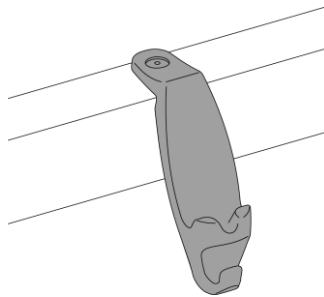

Figure 3.6: Accessory hooks

### 3.8 Equipotential connection

Electric appliances that are directly connected to the patient should be handled with the utmost care. In order to avoid an equipotential difference between the metal bed parts and the floor or other electric appliances connected to the patient, you have to connect all these appliances to a functioning equipotential net.

We would like to refer to the IEC 60601-1:2005; 8.6.7 for more information.

The bed can be connected to the equipotential net by means of the connecting pin, type DIN 42801 under the head end panel.

The equipotential connection is indicated with the following symbol:



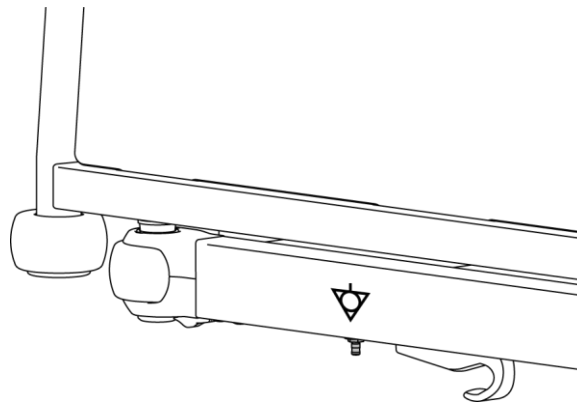

**Figure 3.7: Equipotential connection at a standard head panel**



**The equipotential connection cannot be used as earthing. It can only be connected to an equipotential net that complies with the statutory regulations.**



**Furthermore, you have to opt for an equipotential connection, if the patient can be connected intravascularly or intracardially to medical equipment.**

## IV. CLEANING AND DISINFECTION OF THE BED

### 4.1 General information

You have to check the following items before you start cleaning or disinfecting the bed:

- Have the bed brakes been activated?
- Have the backrest and knee rest been put in a horizontal position? By doing so, you make sure that the interior shaft of the actuator remains greased.
- Have all electric functions been switched off?
- Has the bed been disconnected from the net?
- Have all plugs been put correctly in the control box?
- Have you checked that all cables and electric parts are undamaged?
- Have you made sure that the personnel have appropriate outfits and material? (water-proof aprons and gloves, correct cleaning products,...)



**Ascertain yourself of the fact that the mains cable or electric components are not wet before connecting the bed to the net. If you think that water or disinfectants have seeped into an electric component, you have to disconnect the bed immediately and clearly indicate on the bed that it is “OUT OF USE”. Contact the person who is in charge of the beds as soon as possible. Repairs by unqualified persons may cause severe damage or injuries!**



**All metal protective layers have a high abrasive resistance. Nonetheless, a metal component can have scratches that expose the underlying layer. Always repair this damage to avoid corrosion.**

**After having cleaned and disinfected the bed, it is important to disinfect your hands before going to another area or room.**

**Haelvoet NV cannot be held liable for any damage, injuries and impairments resulting from improper use of cleaning products or disinfectants.**

### 4.2 Degree of protection of the bed: IPX4



**Keep in mind that the bed is not standard wash tunnel-proof. Do not abundantly sprinkle the bed with water. It is absolutely forbidden to use a high-pressure cleaner.**

#### 4.2.1 Cleaning

Remove the linen and wash it. Use a soft cloth - that is moistened with cold or tepid water - and a mild cleaning product or an all-purpose cleaner to clean the bed. Clean the bed afterwards with a moist cloth (without cleaning products) and wipe the bed carefully after the entire cleaning process. Make sure that the mattress platform is completely dry before the mattress is put back.

Avoid:

- Alcoholic cleaning products
- Corrosion-stimulating or aggressive cleaning products
- Cleaning products containing harmful substances
- Scourers
- The composition of your used products may not affect the structure or surface of the synthetic parts. Moreover, the polyester epoxy coating may not be affected as well.

Always read the product information and follow the directions of the cleaning products and disinfectants.

#### **4.2.2 Disinfection**

A good chemical disinfection of the bed can only be obtained by cleaning the bed thoroughly. Always disinfect the bed before a new patient is put in the bed. Take the clinical picture of the patient and the potential presence of infected bed parts into account, and adjust the number of disinfections accordingly. Only qualified and trained personnel, familiar with the effects and use of disinfectants, are allowed to disinfect the bed. Always wear appropriate working clothes, since disinfectants may cause irritations. Always follow the directions of the used product.

- Always use cold or tepid water to dilute the product. Do not use warm water, as this causes vapour. Always seal the dilution.
- Do not use alcoholic products to disinfect large surfaces.
- Avoid skin contact and always wear gloves.
- Always check if the correct quantity has been used.
- Always make sure that there is enough ventilation during and/or after the disinfection.
- Always use a cloth or a rag to disinfect. Do not use spray products (risk of inhalation!).

We would like to refer to the website of the Robert-Koch-Institut ([www.rki.de](http://www.rki.de)) to choose the correct disinfectant. Keep a disinfection journal for each bed and note down when and why the disinfection has taken place. Also write down which disinfectant and which quantity has been used, and do not forget to mention the name and signature of the cleaning person.



# TECHNICAL MANUAL

## V. GENERAL TECHNICAL DESCRIPTION

The design of this hospital bed is the answer to the demand of the hospital and health care sector for a bed providing optimal qualities in the fields of functionality, aesthetics and maintenance. The Olympia Bariatric bed is a multifunctional, height-adjustable bed that maximizes both the comfort of the patient and the user-friendliness.

All steel elements are protected by an epoxy coating or a chromium-plated layer, whereas the hinge points have self-lubricating synthetic bearings (= maintenance-free). Rough surfaces, sharp corners and edges which may cause injuries or damage have been avoided or covered.

A well and preventively maintained bed that is used in accordance with the specifications of this manual can be used for 10 to 25 years (or at least 10,000 cycles per bed function) without any problems. An incorrect or very intensive use of the bed affects its lifespan very negatively. The same goes for bad preventive or curative maintenance. While maintaining the bed curatively or preventively, the technician always has to check if the bed still guarantees the basic safety of the patient or its user. If this is not the case anymore, the bed has to be put out of use.

Do not modify the bed without the explicit permission of Haelvoet NV. After a permitted modification, the bed always has to be inspected correctly. Furthermore, the bed has to be submitted to a thorough test to make sure that the bed still functions safely.

The bed consists of 3 major parts:

- carriage
- bed frame
- mattress platform

Recommend mattress dimensions:

Mattress platform: 91 / 111 / 131 x 206 cm

Mattress: 90 x 195 cm

Minimum mattress thickness: 20 cm

Minimum stiffness of the foam: 2,8 kPa in accordance with ISO 3386 (CLD/40%)

Always use a mattress made of fire retardant material

In case visco-elastic foam is used, a supportive layer of minimum 7 cm with a minimum stiffness of 3,6 kPa in accordance with ISO 3386 (CLD/40%) has to be used.



**If the mattress platform is widened, then it is always necessary to use filling mattresses or a mattress that fits the new mattress platform width, being 90, 110 or 130 cm.**



Figure 5.1: Mattress platform dimensions Olympia Bariatric bed

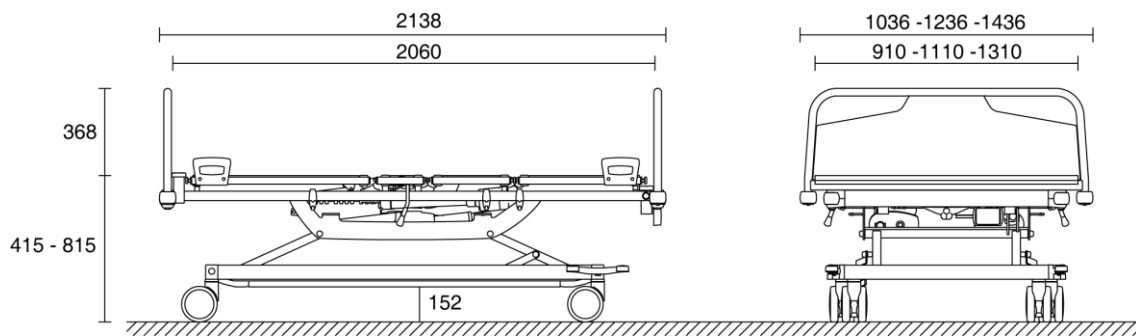
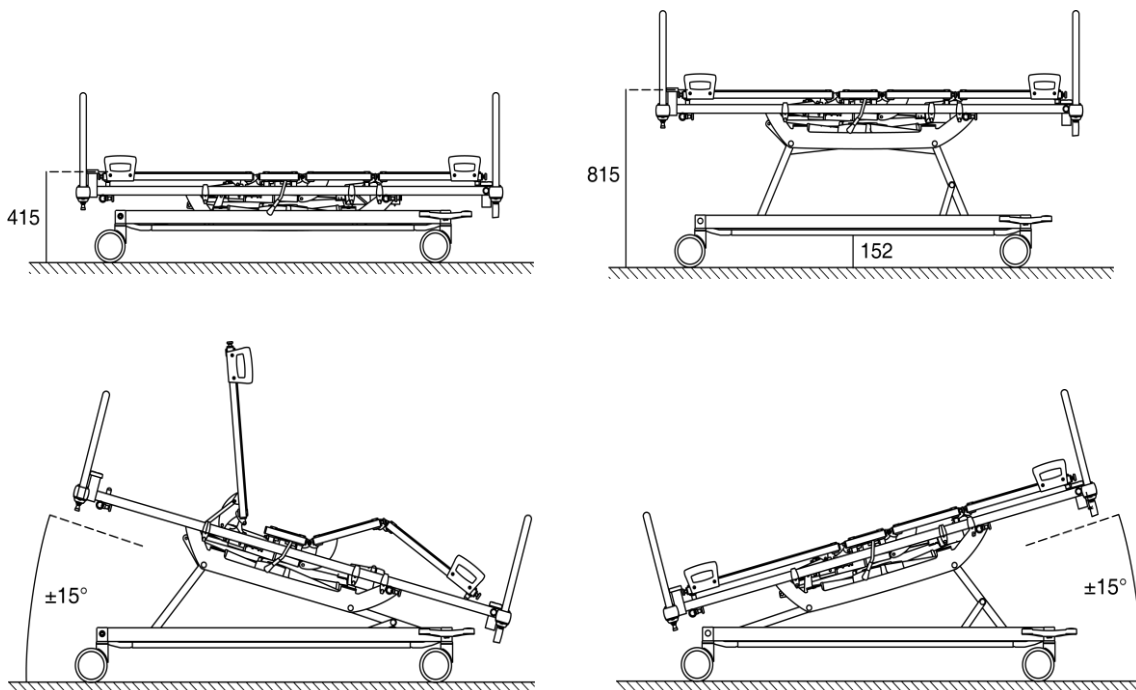
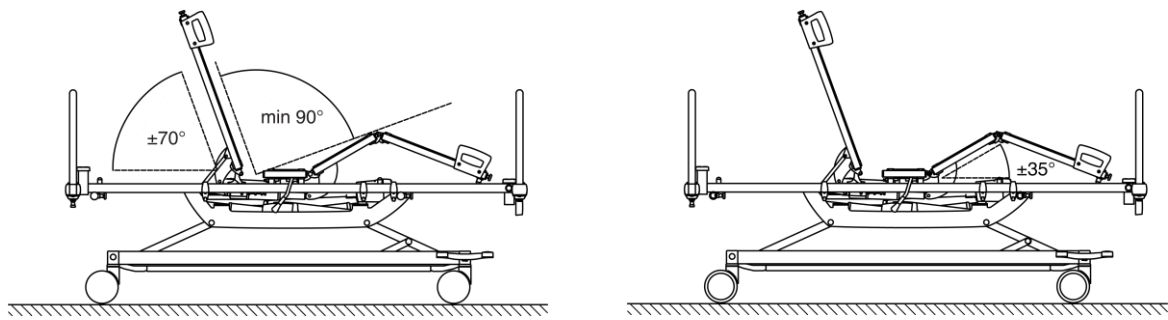

Figure 5.2: Dimensions of the Olympia Bariatric bed





**Figure 5.3: Most important manipulation data of the Olympia Bariatric bed**

## VI. ELECTRIC TECHNICAL DATA

### 6.1 Control box

Type	CB 20
Manufacturer	Linak
Country of production	Denmark
Degree of protection	IPX4
Primary power supply / Max. current intensity	230 VAC / 3 A (110 VAC on request)
Frequency	50 Hz
Secondary power supply	24 VDC
Duty cycle	Max. 10 % or 2 min/18 min
Mains cable length	3 m (spiral cable with strain relief)
Plug type	Moulded three-pin Euro plug

The control box generates a direct current of 24V by means of a transformer. This direct current of 24 V drives the actuators and is not dangerous for the patient and its user.

The control box may only be connected to the mains, as mentioned on the control box label.

### 6.2 Hand switch

Type	HB 8X
Manufacturer	Linak
Country of production	Denmark
Degree of protection	IPX6
Max. current intensity	30 mA

### 6.3 Hand switch HD

Type	HD 8X
Manufacturer	Linak
Country of production	Denmark
Degree of protection	IPX6
Max. current intensity	30 mA

### 6.4 Control panel

Type	ACO(nurse box) or ACC (mini nurse box)
Manufacturer	Linak
Country of production	Denmark
Degree of protection	IPX6
Max. current intensity	100 mA

### 6.5 Battery

Type	Closed lead-acid battery
Manufacturer	Linak
Country of production	Denmark

Degree of protection	IPX6
Input/output voltage	24 VDC
Minimum charge duration (empty)	12 to 16 hours
Capacity	1,2 Ah
Max. storage duration (not connected to the control box)	3 months without recharging
Max. connection duration (built-in battery in the control box)	Advisable to connect the battery to the net at all times.

#### Battery operation:

- When the battery reaches 50% of its capacity, a signal sounds for 1 second (also see 1.9).
- A fully discharged battery is defective and has to be replaced.
- The CB20 with battery back-up only charges the battery when the control box is connected to the mains.
- A battery stored at 25° C has to be recharged every 3 months.
- Prior to the first use of the battery, please make sure that the battery has been charged for at least 12 hours. By doing so, you also prolong the lifetime of the battery.
- The longest lifetime is obtained when the battery is always fully charged.

## 6.6 Backrest actuator with quick release

Type	LA 34
Manufacturer	Linak
Country of production	Denmark
Degree of protection	IP X4
Input voltage	24 VDC
Length of stroke	200 mm
Speed	7-11 mm/s
Sound level	Max. 45 dB(A) DS/EN ISO 3746
Duty cycle	Max. 10 % or 2 min/18 min
Thrust	7000 N
Including	Quick release, clamp safety

## 6.7 Knee rest actuator

Type	LA 31
Manufacturer	Linak
Country of production	Denmark
Degree of protection	IP X4
Input voltage	24 VDC
Length of stroke	60 mm
Speed	3,6-6 mm/s
Sound level	Max. 45 dB(A) DS/EN ISO 3746
Duty cycle	Max. 10 % or 2 min/18 min
Thrust	6000 N
Including	Clamp safety

## 6.8 High-low actuators

Type	LA 44
Manufacturer	Linak
Country of production	Denmark
Degree of protection	IP X4
Input voltage	24 VDC
Length of stroke	150 mm
Speed	3.6 – 6 mm/sec
Sound level	Max. 45 dB dB(A) DS/EN ISO 3746
Duty cycle	Max. 10 % or 2 min/20 min
Thrust	12000 N
Including	<i>Safety nut</i>

## 6.9 Specifications off the CB 20 control box

### a. Fatal error

- Error indication:
  - all ACO LEDs are blinking
  - The CB20 buzzer gives the 'fatal error' signal.

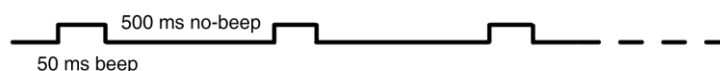

- The error can be reset. You have to press the buttons 'knee rest down' and 'backrest down' simultaneously on the hand switch. Put the mattress platform in its highest position to reset the CB20. Check if all ACO LEDs are not activated. If not: repeat the reset procedure. During this procedure, it is possible that the control box gives the acoustic signal "Manual mode" or Reset of Fatal error'.

Signal 'Manual mode':

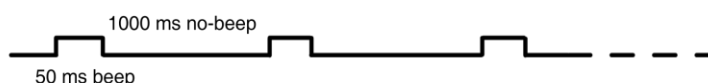

Signal 'Reset of Fatal error':

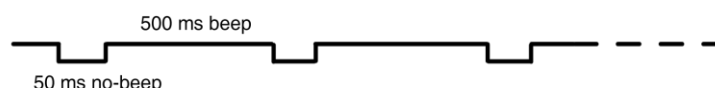

### b. Overload

When the bed is overloaded, the available capacity of the transformer is divided among the actuators in the following order: high/low head end, high/low foot end, backrest, knee rest.

Long load can result in 'overheating' (acoustic signal "Overheating" or "Hoot" see 1.9). The pace of the bed will decrease substantially. The bed can be operated at a lower pace to protect the safety of the system and increase the safety of the patient). If this happens: do not use the bed for 12 hours.

Signal "Overheating"

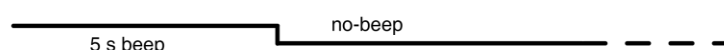

Signal "Hoot"



### c. Position Lost

If 1 or more actuators don't reach their end position when activating a control button, the "Position Lost" signal will sound.



• Error indication:

- all ACO LEDs are blinking.
- The CB20 buzzer gives the "Position Lost" signal.
- The error can be reset with the same procedure for "Fatal error" situations.

d. Nurse box & mini-nurse box

Both the arrow and the function buttons on the nurse box have to be continuously pressed at all times to manipulate a function via this unit. (see chapter II)

e. Internal protection of the control box

The control box is internally protected by a safety fuse.

Remark: at the customer's request, the bed can be delivered with the corresponding electric parameters that are statutory in the respective country (Voltage, mains cable plug).

## 6.10 Ambient conditions for the actuators

Temperature:	5°C to 40°C
Relative humidity:	20 % to 90 % at 30°C without condensation (for IP X4)
Atmospheric pressure:	700 to 1060 hPa

## 6.11 Precautions for cable connections



**Never install/remove a cable or actuator when the control box is connected to the net and/or a bed function has been activated.**

The following procedure has to be followed when replacing a cable:

1. Disconnect the bed and wait for 5 seconds.
2. Remove/install the necessary cable and/or actuator.
3. Check if all cable fittings have been equipped with a rubber o-ring. Install the cables and lock them by using the correct locking mechanism.
4. Connect the bed to the net and test its functionality.

Not following this procedure can result in a damaged control box.

Non-used connections have to be closed with correct cover caps to guarantee the mentioned IP-degree.



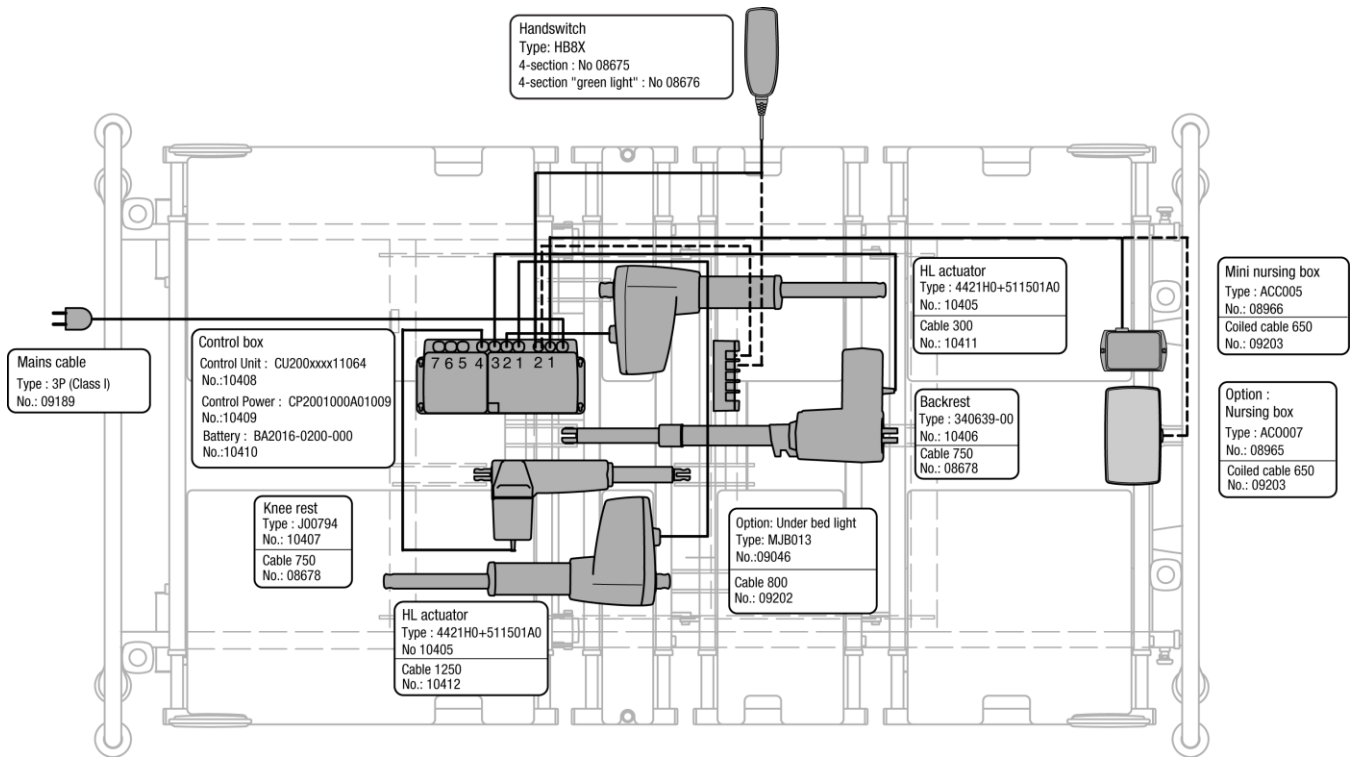

Figure 6.1: Circuit diagram Olympia Bariatric

## VII. MECHANICAL TECHNICAL DATA

Bed type	Olympia Bariatric
Weight of an empty bed without options	209 kg
Degree of protection	IP X4
Safe working load	500 kg*
Max. sound level during a manipulation	max 50dB(A)

\* It should be taken into consideration that the safe working load can only be realised, if the bed is loaded as mentioned in the norm EN 60601-2-52 (i.e. backrest 45 %, fixed section 25 %, knee rest and footrest 30 %).

## VIII. TECHNICAL DATA CASTORS

Type	Twin castor series 559X Ø125 mm, central braked
Manufacturer	Steinco
Country of production	Germany
Castor diameter	150 mm
Castor width	108 mm
Bearing	Precision ball bearings
Dynamic load capacity	200 kg
Static load capacity	600 kg
Load	2000 N
Swivelling resistance	60 N
Rolling resistance	20 N
Tread	Polyurethane
Operating angle of the central brake	30°

## IX. STORAGE OF THE BED

Before storing the bed, you have to make sure that:

- the bed and the mattress platform sections have been put in their lowest position.
- the central brake has been activated.
- all electric functions have been switched off.
- all accessories have been removed.
- ***the internal battery has to be charged every week, in case the bed is stored for more than one week.***
- the bed has been covered.
- the storage space is dry and dust-proof (relative humidity of 20 to 90% without condensation).
- the temperature remains relatively constant and lies between -10 and +50°.
- the atmospheric pressure lies between 700 hPa and 1060 hPa



**You have to check all functions before you want to use the bed again (see checklist in appendix).**

## X. PREVENTIVE AND CURATIVE MAINTENANCE

### 10.1 Safety responsibility

It is the responsibility of the institute to make sure that the bed guarantees the patient's safety during its entire life span. For this reason, the safety of the bed has to be checked regularly. Moreover, the bed has to be maintained preventively. The bed has been developed in such a way that it can be used safely for many years, on the condition that it is manipulated correctly and checked regularly. It also has to get at least one preventive maintenance a year.

It is the nurses' task to perform a routine check at regular times, especially when a new patient has to be put in the bed.



**The maintenance of the bed may only be carried out by qualified and technically trained personnel. The guarantee is nullified, if the maintenance of the bed has been carried out unprofessionally and causes damage to the bed functions.**



**All repairs to actuators, control boxes and actuator accessories have to be carried out by an authorised Linak service shop or by a technician that has been acknowledged by Linak. All guarantee conditions are nullified, if Linak parts have been opened. An acknowledged Linak technician can always obtain further information about Linak parts from Haelvoet or Linak.**



**Never perform maintenance work or repairs while the patient is still in the bed.**



**In order to optimize the life span of the bed and to avoid accidents, the European regulation obliges an annual preventive and registered maintenance. Use the checklist in appendix during this annual preventive maintenance. If necessary, consult this manual as well.**

The standard IEC EN 62353 - Medical electrical equipment - Recurrent test and test after repair of medical electrical equipment - can be used as a guide for a good maintenance procedure.

In addition to the annual registered preventive maintenance, we strongly recommend you to check the following items regularly:

- All electric functions.
- All mechanical functions (sideguards, castors,...).
- All cables and especially the mains cable.
- The hand switch and the connection cables
- Always check the mains cable when the bed has been moved and before connecting it to the net again.

When you think that there is some damage or that the bed does not function properly, you have to stop using the bed immediately. You also have to indicate clearly on the bed that it is OUT OF USE. Contact the person who is in charge of the beds as soon as possible.

The checklist in appendix can serve as a guideline during controls.

## 10.2 Spare parts

Haelvoet NV can provide all necessary spare parts. All you have to do, is to specify the article number, the sales order number and the serial number of the respective product. This information can be read on the identification label. This label is to be found on the side beam of the bed frame at the head end.

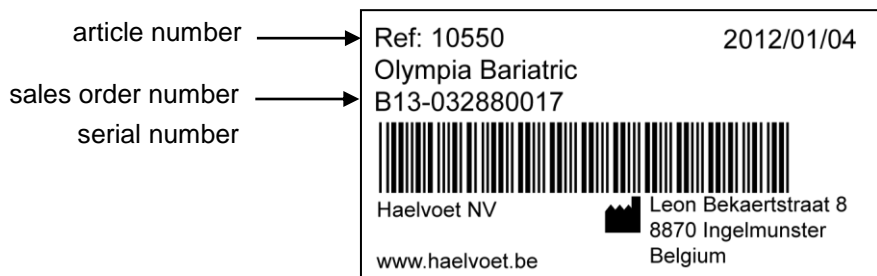

In order to keep the right to the guarantee, you are only allowed to use original Haelvoet NV spare parts. This instruction also applies to further maintain the safety of the bed.

Do not hesitate to contact Haelvoet NV if you have specific questions or if you want to order spare parts:

**Haelvoet nv**  
**Leon Bekaertstraat 8**  
**8870 Ingelmunster**  
**Belgium**  
**Tel: +32 (0) 51 48 66 95**  
**Fax: +32 (0) 51 48 73 19**  
**Email: [info@haelvoet.com](mailto:info@haelvoet.com)**  
**[www.haelvoet.com](http://www.haelvoet.com)**

## 10.3 Used fastening methods

- axle retaining ring: This ring is used to fasten the control box, the mattress platform actuators and the metal parts. It can be easily removed by just pulling the clip. The axle can be locked again by pushing the retaining ring back in the groove.

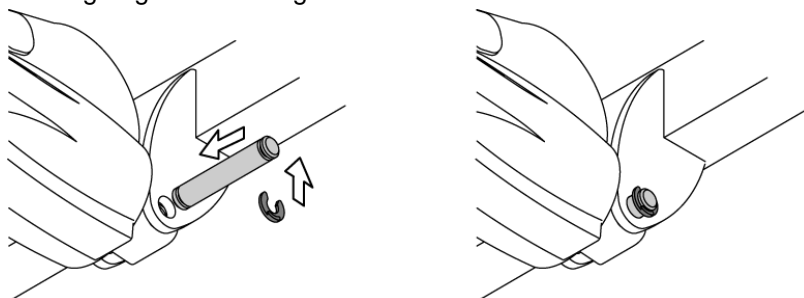
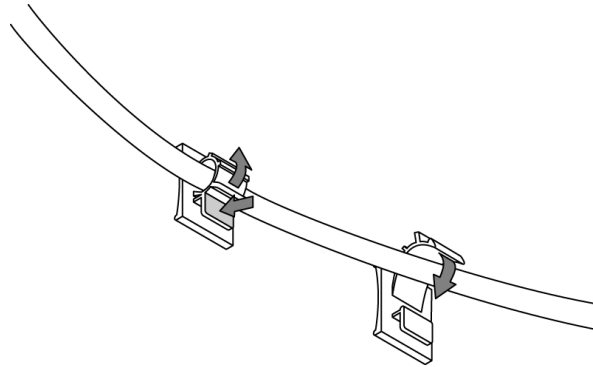

Figure 10.1: Axle and axle retaining ring

- cable clamp: All cables are fastened by means of clamps that can be removed and locked without needing any tools. Make sure that all cable clamps are locked properly after a cable has been replaced (risk analysis).



**Figure 10.2: Cable clamp**

## 10.4 Replacement of a high/low actuator

1. Put the bed in a position as high as possible.
2. Support the mattress platform at the head and foot end so that it cannot fall suddenly.
3. Disconnect the actuator cable from the actuator. It is advisable to check if the actuator you have to replace is really damaged. This is possible by plugging a new actuator in the control box without actually building it in, and checking its functions.
4. First remove the axle at the side of the HL arm. Do not forget to support the actuator so that it cannot swivel downwards. After this, the second axle near the suspension point can be removed, making it possible to remove the actuator from the bed.

The opposite working method has to be followed to install an actuator in the bed.

## 10.5 Replacement of a mattress platform actuator

1. Disconnect the bed from the net.
2. Remove the load (e.g. mattress) from the mattress platform that exerts pressure on the actuator.
3. Disconnect the actuator from the control box. It is advisable to check whether the actuator is really damaged. This is possible by plugging a new actuator in the control box without actually building it in, and checking its functions.
4. First, you have to get the bar that activates the mechanical quick release (CPR) out of the quick release, before you remove the backrest actuator. This can be done by removing the cover of this mechanism.
5. Open all cable clamps and remove the axle retaining ring from both axles.
6. First remove the axle on the side of the moving mattress platform section, but make sure that the moving mattress platform section and/or the actuator cannot come loose and/or fall. Afterwards, the second axle can also be removed, making it possible to take the actuator out of the bed.

The opposite working method has to be followed to install an actuator into the bed.



When you want to put back a removed actuator cable in the actuator or the control box, you always have to make sure that this happens correctly. Always plug in the cable as deep as possible and fasten the protective cap again. This is necessary to guarantee a reliable sealing and functioning. Always make sure that the cables are fastened in such a way that they cannot be damaged (no loops, kinks or incisions).



Only persons that have been acknowledged by Linak are allowed to open and repair an actuator. Always replace the entire electric part without opening it. Only a qualified technician is allowed to replace an actuator.

## 10.6 Readjustment of the CPR lever

1. Put the backrest in a horizontal position.
2. The nut on the thread end has to be adjusted in such a way that the lever doesn't have any clearance. Do not pull the lever too tight, because this can trigger an unforeseen activation of the CPR without any manipulation.
3. Put the backrest in an inclined position and check if the quick release functions properly when there is a person in the bed.



Figure 10.3: Quick release

## 10.7 Adjusting the speed of the quick release/CPR lever

The backrest is put in a horizontal position by activating the CPR lever. If wanted, the speed of this process can be adjusted. To do so, put a flat screwdriver in the red section of the backrest actuator. When turning this screwdriver clockwise (indicated with "-"), the speed will decrease. When turning this screwdriver anticlockwise, (indicated with "+"), the speed will increase.

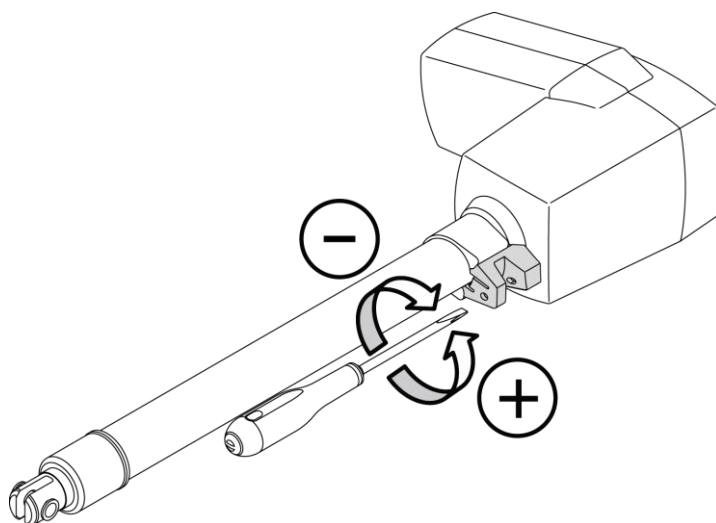

Figure 10.4: Adjusting the quick release mechanism/ CPR lever mechanism

## 10.8 Battery

### Technical specifications:

*Type:* closed lead-acid battery with a capacity of 1,2 Ah

*Life span at normal use:* minimum 3 years. The way of use can shorten this life span considerably.

*Operating time:* depending on the kind of movement (HL, back or knee rest) and load. A height variation requires the largest amount of current (2 parallel actuators). 6 to 10 complete high/low cycles can be carried out when there is a load of 200 kg. Obviously, a lot more manipulations are possible for a back and knee adjustment. An alarm signal warns you during an electric manipulation, in case the capacity of the battery does not suffice anymore to manipulate the bed. Immediately connect the bed to the net as soon as this alarm signal is audible.

Charge the battery completely before you start using the bed (at least 12 hours). Multiple high discharges have a harmful effect on the life span of the battery.

### Description:

Linak uses *closed lead-acid batteries*. Given its long-time experience in using this type of battery, Linak considers the closed lead-acid battery as the safest battery available at the moment. To prevent potential problems, we strongly recommend you to follow the maintenance advice as described hereunder:

- The battery sets have an average life span of minimum 3 years, when used correctly. Frequent discharges have a harmful effect on the life span of the battery. It is recommended to connect the control box as much as possible to the net, so that a long life span of the battery is guaranteed. It is also necessary to charge a battery that is not built-in, and not used, at least every 3 months. In this way, you prevent a self-discharge of the battery.
- Irrespective of its use, the battery must be replaced every 5 years. If you use the battery for a longer period, it can damage the controlbox and/or the battery.
- Replaced batteries go via Linak or Haelvoet to the recycling cycle, or may be recycled in the same way as car batteries.

### Annual preventive battery check:

Make sure that the battery is completely charged before it is tested. Disconnect the bed from the net and put a weight of about 200 kg on the mattress. The battery should be able to carry out at least one or two complete high/low cycles without any problems. If this is not the case, it is advised to replace the battery immediately.



If the battery is damaged because of a shock (e.g. because it has fallen on the floor), it is important that it is checked and replaced in case of visual damage.



Always replace a battery that is older than 5 years or of which the capacity is too low. Faulty or old batteries increase the risk of explosion.



## 10.9 Replacement of the mains cable

If the mains cable is damaged, you have to replace it immediately. You have to follow the instructions described hereunder to replace the mains cable correctly:

1. Disconnect the plug from the net.
2. Release the strain relief. The strain relief is situated at the head end, underneath the backrest. The bed can be equipped with two different types of strain relief:

### Strain relief type 1

Unscrew the metal nut and remove the mains cable from the fixing groove.

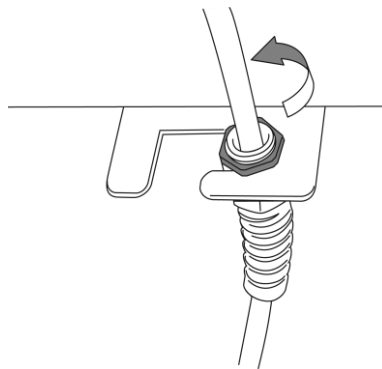

**Figure 10.5: Release of the strain relief type 1**

### Strain relief type 2

Unscrew both screws from the synthetic strain relief and loosen the upper part. The mains cable can be removed now.

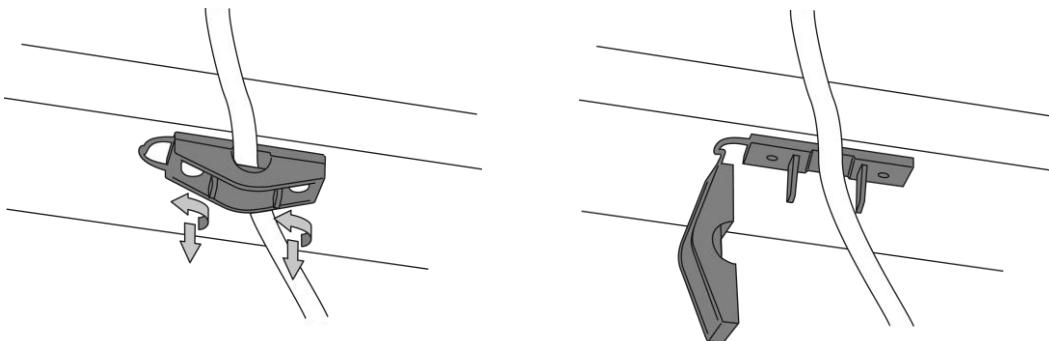

**Figure 10.6: Release of the strain relief type 2**

3. Disconnect the mains cable from the control box. To do this, you have to push in two red pins, while pulling the plug out of the control box. A flat screwdriver is the best tool to push in these red pins. To install the mains cable, you have to push in both pins while you plug in to the control box. Make sure that both pins are anchored properly in the control box. You can check this pulling the plug.

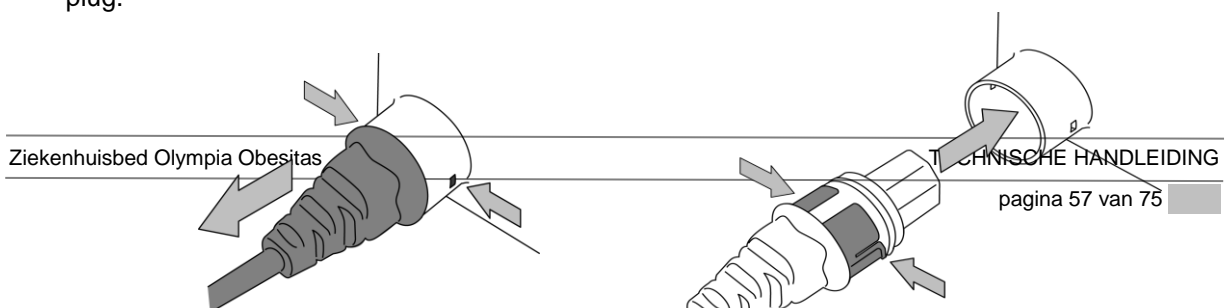

**Figure 10.7: Replacement of a mains cable in the control box**

4. Install the strain relief again. Make sure that the strain relief is fixed properly and not damaged. The strain relief has an extremely important function: it avoids traction on the control box in case the mains cable is used incorrectly.

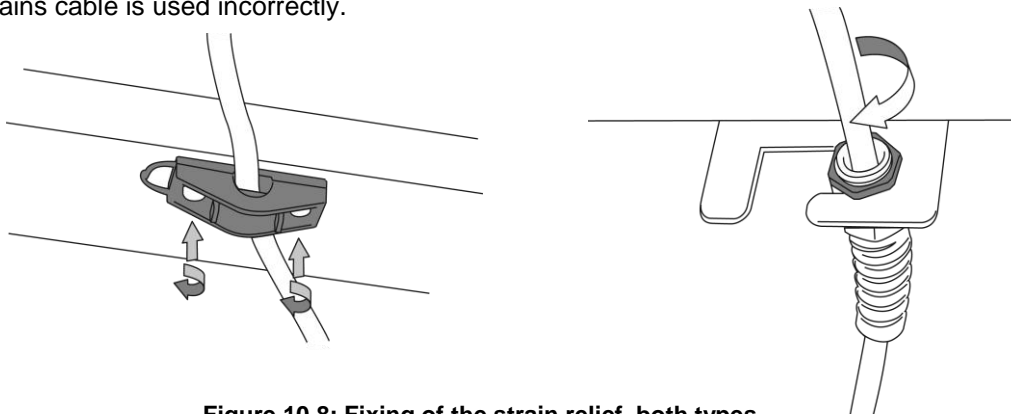

**Figure 10.8: Fixing of the strain relief, both types**

## 10.10 Replacement of a control box

Disconnect the control box CB20 from the net. Unplug the control box completely. Push the resilient plate of the suspension to the left and remove the control box. Install a new control box and connect all plugs again (see circuit diagram, figure 6.1).

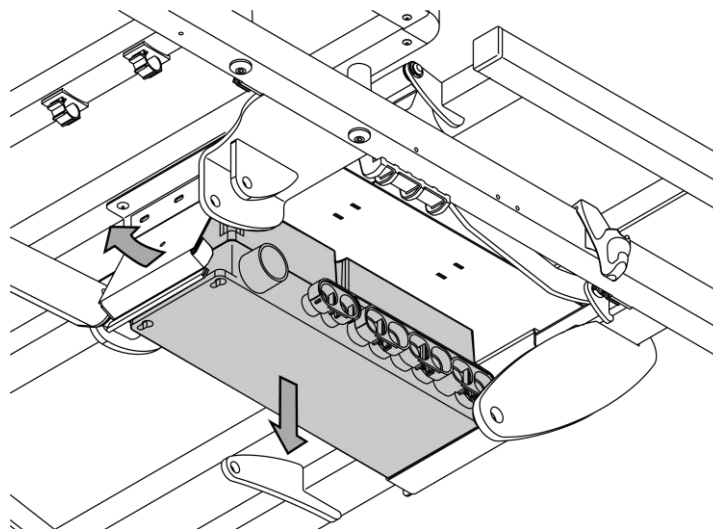

**Figure 10.9: How to replace the control box CB20**

## **XI. POSSIBLE PROBLEMS**

### **Problem 1: The bed is acting slower than normal.**

#### **Is the bed connected to the (electricity) net?**

- No -> The bed is functioning on its battery, which is slowing down the functions.
- Yes -> Please check if the bed is not too much charged/loaded (too much weight on the bed)?

#### **Is overload the cause of reducing the speed of the operations ?**

- Yes -> Please lower the charge/ the load of the bed and don't use the bed for a couple of hours.
- No -> Please check the voltage of the net.

### **Problem 2: Not all functions of the bed are working.**

#### **Are some functions on the nurse box not blocked?**

- Yes-> Please unlock the blocked functions on the nurse box.

#### **Are the lights on the nurse box not flashing ?**

- Yes-> Please implement the reset procedure. (please ask for reset procedure document)
- No-> Please check if all cables are well plugged in, as well as please check the condition of the cable of the actuator that is not functioning. In the worse case a new cable have to be installed.

#### **Is the problem solved?**

- No-> Please connect a new actuator onto the control box and check it's functioning with the hand control.

#### **Is the problem solved?**

- Yes-> Install the new actuator on the bed.
- No-> Replace the handcontrol or the nurse box.

### **Problem 3: One of the hand control units are not working.**

**Please check if the hand controls are well plugged in as well as check the condition/ the functioning of their cables. Move the cable when activating a function of the hand control. If needed replace the hand control unit.**

### **Problem 4: no functions are working at all.**

#### **Is the bed connected to the net?**

- No-> The battery is completely empty. Please connect the bed to the net

#### **Is the green light of the control box lighting up?**

- Yes-> Please check if the functions are not blocked on the nursing box (ACO box)
- No-> Check the condition of the feeding cable (in between net & control box) as well as check the voltage of the net

**\*Reset: See Fig 2.8**

## XII. ACCESSORIES

Only the following accessories that have been acknowledged by Haelvoet can be used for the bed. If you use other accessories, Haelvoet NV cannot be held liable for any possible accident, malfunction or damage.

<i>IDnr</i>	<i>Accessory</i>	<i>IDnr</i>	<i>Accessory</i>
00441	Flexible hand switch holder	05876	Urine bottle holder (horizontal)
01840	Lifting pole	03799	Writing table
01856	IV rod	05878	Bowl holder
01862	Name card holder	06366	Oxygen bottle holder
01863	Synthetic file holder A4 (horizontal)	09242	Bed pan holder
01864	Synthetic file holder A4 (vertical)	09603	Monitor/device holder
03576	Synthetic file holder A3 (horizontal)	09629	Accessory brace
03272	Traction brace	10771	Removable mattress platform extension
03296	Urine bottle holder (vertical)		



Keep the following information in mind when using the sideguards, IV rods,... on electrically adjustable beds:

When using the high/low function, the backrest or knee rest, you have to make sure that the patient does not get stuck because of accessories. If this cannot be guaranteed, then the nurse has to prevent that the patient can use the high/low function, backrest and knee rest.

This can be done by placing the hand switch outside the reach of the patient (e.g. at the foot end of the bed), or by blocking these functions (by means of the nurse box or mini nurse box)

## XIII. GUARANTEE

The contractual guarantee is nullified, if spare parts are used that are not permitted, or if non-authorized interventions or actions are performed, such as:

- Opening an actuator, control box, hand switch, battery or any other electric or electronic part.
- Cleaning of an IPx4 bed in a wash tunnel or cleaning with unauthorized products.
- Incorrect use or incorrect assembly.
- Activations that conflict with the instructions in this manual.
- Activations that exceed the expectations of a bariatric hospital bed.

**The stipulated guarantee period in the contract is only valid if a “registered” preventive maintenance is performed annually.**

**Spare parts that are covered by the guarantee will only be credited when the faulty parts are returned.**

## XIV. RESIDUAL WASTE AND THE ENVIRONMENT

Please sort the residual waste in accordance with the regulatory environmental requirements. Replaced electric parts such as actuators, control boxes and hand switches have to be processed as electronic waste. If you decide not to use the bed any longer and to destroy it, then the bed has to be disassembled and recycled in accordance with the environmental legislation.

This product contains recyclable aluminium, steel, synthetic material and electronic components. In order to recycle optimally at the end of the bed's life span, all parts have to be separated in such a way that the basic materials of this product can be used again.

Haelvoet NV is fully aware of the fact that the environment has to be protected for the next generations. That is why we pay extra attention to development, innovation, production and the use of environment-friendly technologies and materials.



This logo wants to point out to the consumer that waste belongs in a dustbin and not in natural areas or on the public highway.



This symbol – known as the möbius loop – can mean two things: “Recyclable” product or “This product contains recycled material”. If the latter is the case, then the word ‘recycled’ has to be mentioned.

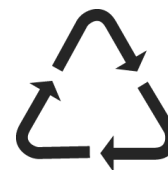

Recyclable synthetic material. A number refers to the sort of plastic that is used to make the product. For the moment, only plastic types 1, 2 and 3 can be recycled.

Plastic types:

- 1 = PET
- 2 = HDPE
- 3 = PVC
- 4 = LDPE
- 5 = PP
- 6 = PS
- 7 = other types

This product is made of environment-friendly materials! It does not contain any dangerous substances such as cadmium, mercury, asbestos, PCBs or CFCs. The sound level of the bed complies with the regulatory demands to protect the public health against unwanted noise and vibrations in a protective interior area.

This product has a lead-acid battery. When the life span of the battery has come to an end, hand in this battery to a person or institute that is authorized for battery collection.

### **Information for the users of electric and electronic equipment.**



This symbol on the product or supplied documentation means that the used electric or electronic components may not be given or destroyed with domestic waste. Only specialised firms are authorized to process this waste. These firms will accept your waste without charge.

By removing and recycling these components properly, you protect valuable natural resources. You also prevent possible negative effects on public health. Further information can be obtained from the governmental agencies that are officially acknowledged for the protection of the environment, or from the nearest assembly point for the collection of separated waste.



**If you don't follow the correct procedures for waste disposal, the national legislation can seriously fine you!**

### **Information about the disposal of electric and electronic equipment for users in countries outside the European Union:**

The symbol as showed above only applies for countries of the European Union. Please consult your local authorities or distributor for more information about the correct disposal of OEEZ/WEEE (waste of electric and electronic equipment) and lead-acid batteries.

**Protect your health and the environment.**

**Protecting the environment is protecting the future. Thank you.**

## XV. SYMBOLS



Backrest adjustment



High-low adjustment

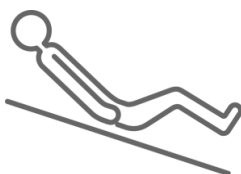

Relax/ seat adjustment



Block function

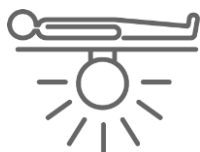

Nightlight under the bed



Warning

Not following this instruction can lead to accidents with serious injuries.



Not following this instruction can lead to material damage to the bed and/or surroundings.



Knee rest adjustment



Trend – Reverse-Trend



Sleeping function



Battery charge indicator



Magnetic key



Forbidden

## XVI. CONFORMITY

The Olympia hospital bed is produced in accordance with ISO 9001:2008 and complies with the European Medical Devices directive 93/42/EEC and all applicable European harmonized norms:

**EN 60601-1** Medical electrical equipment. Part 1: General requirements for basic safety and essential performance.

**EN 60601-1-2** Medical electrical equipment. Part 1-2: General requirements for safety and essential performance – Secondary norm: Electromagnetic compatibility – Requirements and tests.

**EN 60601-2-52** Medical electrical equipment. Part 2-52: Particular requirements for basic safety and essential performance of medical beds.

**EN ISO 14971** Application of risk management to medical devices.

### 16.1 Explanation CE-label and identification-label

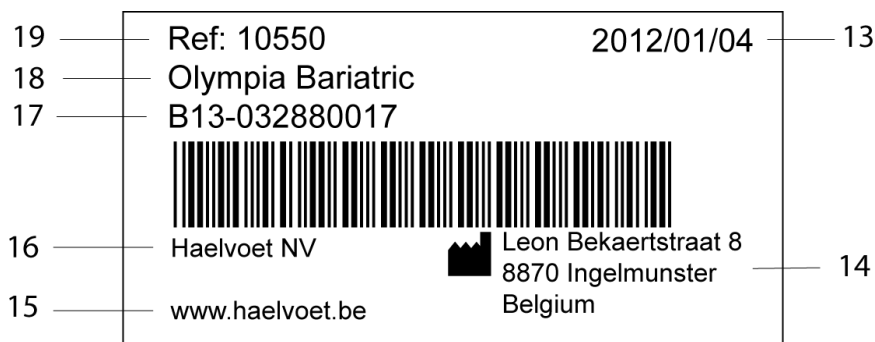
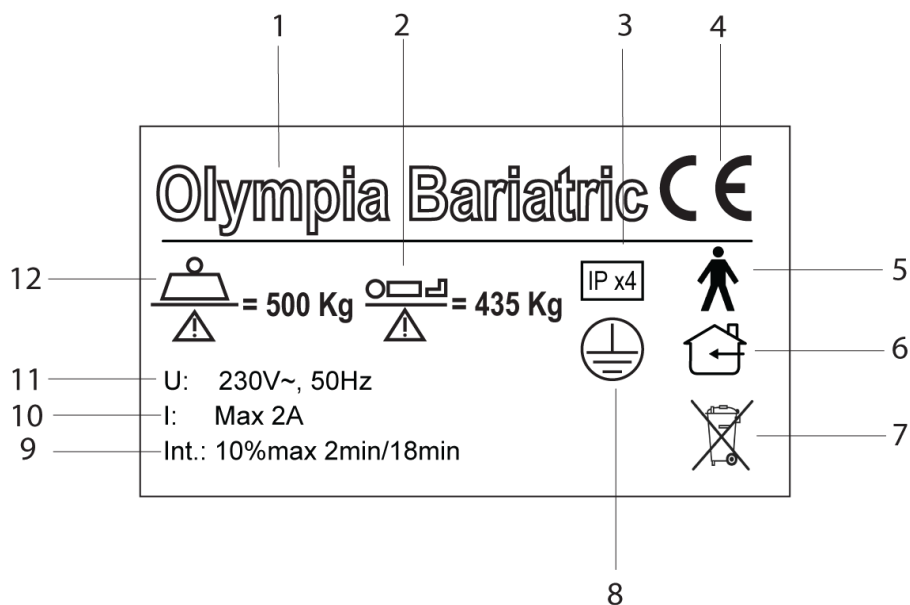



2	Safe patient load	11	Input voltage
3	Protection against splashing water coming from all directions	12	Sage working load
4	Conformity mark in accordance with the directive for medical equipment 93/42/EEC	13	Date of manufacture
5	Type B equipment according to EN 60601-1	14	Address manufacturer
6	To be used indoors	15	Website manufacturer
7	Attention! Electronic waste	16	Manufacturer
8	Class I equipment	17	Series number / Sales order number
9	Move for a maximum of 2 minutes, then 18 minutes pause	18	Name Article
		19	Article number

## 16.2 Symbols

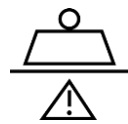

Safe working load

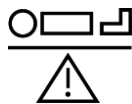

Safe patient weight



Type B equipment according to EN 60601-1



Protection against splashing water coming from all directions.

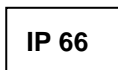

Protection against dust and powerful jets of water coming from all directions.



Class I equipment



Class II equipment



To be used indoors

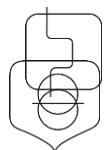

Thermal switch off in the transformer

Double insulated transformer

Equipotential connection



Conformity mark in accordance with the directive for medical equipment 93/42 EEC



Obligated reading of the manual before using the bed



Consult the instructions for use



Warning



Incompatible mattresses can be dangerous, consult the instructions for use.



The used electric or electronic components may not be given or destroyed with domestic waste.



Direction of the head, obliged reading of the manual before using the bed



Clamping danger hands

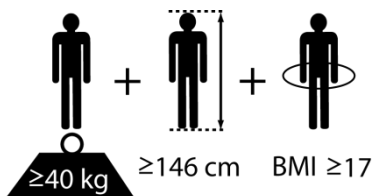

Physical description of an adult patient

# APPENDIX 1: EC-DECLARATION

## EC- DECLARATION OF CONFORMITY

Following the EC Directive concerning medical devices 93/42/EEC, annex VII.

I, the undersigned, agent of the following manufacturer:

**Haelvoet nv**

**Leon Bekaertstraat 8**

**8770 Ingelmunster**

**Belgium**

**Tel.: +32 (0) 51 48 66 95**

**Fax: +32 (0) 51 48 73 19**

**Email: [info@haelvoet.com](mailto:info@haelvoet.com)**

Declare hereby that the following product:

**Olympia Bariatric**

**No.: 10550**

Medical device class I (non-invasive device)

when installed, maintained and used in accordance with the manual, the rules of good craftsmanship, and the intended purpose complies with all necessary safety requirements and other relevant provisions of annex I of:

### Medical Devices directive 93/42/EEC

The following norms have been applied to indicate the conformity:

- |                      |   |
|----------------------|---|
| <b>EN 60601-1</b>    | Medical electrical equipment. Part 1: General requirements for basic safety and essential performance.  |
| <b>EN 60601-1-2</b>  | Medical electrical equipment. Part 1-2: General requirements for safety and essential performance – Secondary norm: Electromagnetic compatibility – Requirements and tests. |
| <b>EN 60601-2-52</b> | Medical electrical equipment. Part 2-52: Particular requirements for basic safety and essential performance of medical beds.  |
| <b>EN ISO 14971</b>  | Application of risk management to medical devices.  |

The conformity to the mentioned harmonised norms is certified by:

**TÜV SÜD Product Service GmbH**

**Approval certificate Z1 13 08 84536 005**



The above-mentioned product has been designed, produced and checked in accordance with the quality management system of **ISO 9001:2008**.

**Ingelmunster, 02/03/2012**

**Signature:**

A handwritten signature in blue ink, appearing to read 'Haelvoet Vincent'.

**Haelvoet Vincent  
Managing director**

## APPENDIX 2: CHECKLIST MAINTENANCE

<b>Customer:</b>			
<b>Address:</b>			
<b>Performed:</b>	<input type="checkbox"/> check on delivery	<input type="checkbox"/> periodical check	
<input type="checkbox"/> other	<input type="checkbox"/> check after repair or maintenance		
<b>Bed type:</b>	<input checked="" type="checkbox"/> Hospital bed	<input type="checkbox"/> Nursing bed	<input type="checkbox"/> Protection class: I <input type="checkbox"/> Protection class: II
<b>Model:</b>	Olympia Bariatric	<b>Id nr.:</b>	
<b>Installation:</b>			
<b>Manufacturer:</b>	Haelvoet nv		
<b>Class:</b>	Class I Medical Device		
<b>I. Visual check</b>	<b>Good</b>	<b>Not good</b>	<b>Malfunction description</b>
<b>Visual check of the electric parts</b>			
Stickers and identification plates	Present		
Housing of the control box	Correct position, damage		
Housing of the actuators	Correct position, damage		
Battery	Age		
Fixation of the actuator shafts	All fastening clips are present		
Hand switch	Damage		
Actuator, hand switch supply cables	Damage, because the cable is jammed or cut/incised. Check the cable route and fixation		
All plug connections with the control box	Plugged in correctly, bayonet lock is present + installed correctly		
Strain relief of the supply cable	Supply cable is fastened properly		
Equipotential connections (optional)	Damage, fastened properly		
<b>Visual check of the mechanical parts</b>			
Stickers and identification plates	Present		
Carriage	Damage, deformation		
Castors	Damage		
Mattress platform sections	Damage, deformation		
Welded joints	Broken joint		
Sideguards	Damage, deformation, compliance with the statutory norm		
Wear-sensitive parts, such as hinge points	Wear, breakage		
All nuts/bolts			
Lifting pole	Damage, deformation		
Lifting pole handle	Damage, deformation		
Lifting pole ribbon	Damage (fraying)		
<b>II. Electric measurement in accordance with EN 62353</b>	<b>Good</b>	<b>Not good</b>	<b>Malfunction description</b>

III. Performance check		Good	Not good	Malfunction description
<b>Performance check of the electric parts</b>				
Performance of all actuators and control box	Test as instructed by the manual			
Sound of all actuators and control box				
Battery	Performance			
Hand switch	Functioning, sound, lock functions Position and functioning of the magnet of the HD-Hand switch (option)			
Lock box, locking mechanism	Test as instructed by the manual			
Limit switch on the actuators	Automatic			
High/Low foot pedal (optional)	Functioning			
Brake buzzer (optional)	Functioning			
<b>Performance check of the mechanical parts</b>				
Complete bed functionality				
Hinges and virtual pivot points	Smooth, fluent movement Lubrication with vaseline			
Castors	Brakes, unblocking			
CPR lever	Functioning as mentioned in this manual			
Sideguards	Functioning, blocking			
Bed and foot extension	Fluent functioning			
Footrest or legrest adjustment	Telescopic adjust functions properly			
Bumpers	Functioning			
Lock box	Functioning of the slide Length of the cable			
<b>Check results</b>				
<b>All check results are within the permitted limits</b>	<input type="checkbox"/> yes <input type="checkbox"/> no		<b>Next date of inspection:</b>	
<b>Successful check</b>	<input type="checkbox"/> yes <input type="checkbox"/> no			
<b>Unsuccessful check</b>	<input type="checkbox"/> Malfunction, do not use the bed! ⇒ repair <input type="checkbox"/> Malfunction, do not use the bed! ⇒ put the bed OUT OF USE <input type="checkbox"/> Bed does not comply with the safety norm			
<b>Test sticker is present</b>	<input type="checkbox"/> yes <input type="checkbox"/> no			
<b>Other remarks</b>				
<b>Comments</b>				
<b>Datum of inspection:</b>	<b>Inspector:</b>		<b>Signature:</b>	

# APPENDIX 3: EMC-TABLES

<p style="text-align: center;"><b>Guidance and manufacturer’s declaration – electromagnetic emission</b></p>		
<p>The OLYMPIA BARIATRIC bed is intended for use in the electromagnetic environment specified below. The customer or the user of the OLYMPIA BARIATRIC bed should assure that it is used in such an environment.</p>		
Emissions test	Compliance	Electromagnetic environment - guidance
RF emissions CISPR 11	<b>Group 1</b>	<p>The OLYMPIA BARIATRIC bed uses RF energy only for its internal function. Therefore, its RF emissions are very low and are not likely to cause any interference in nearby electronic equipment. The OLYMPIA BARIATRIC bed is suitable for use in all establishments, including domestic establishments and those directly connected to the public low-voltage power supply network that supplies buildings used for domestic purposes.</p>
RF emissions CISPR 11	Class B	
Harmonic emissions IEC 61000-3-2	Class A	
Voltage fluctuations / flicker emissions IEC 61000-3-3	Complies	

## Guidance and manufacturer's declaration – electromagnetic immunity

The OLYMPIA BARIATRIC bed is intended for use in the electromagnetic environment specified below. The customer or the user of the OLYMPIA BARIATRIC bed should assure that it is used in such an environment.

Immunity test	IEC 60601 test level	Compliance level	Electromagnetic environment - guidance
Electrostatic discharge (ESD) IEC 61000-4-2	± 6 kV contact ± 8 kV air	± 6 kV contact ± 8 kV air	Floors should be wood, concrete or ceramic tile. If floors are covered with synthetic material, the relative humidity should be at least 30 %.
Electrostatic transient / burst IEC 61000-4-4	± 2 kV for power supply lines ± 1 kV for input/output lines	± 2 kV for power supply lines ± 1 kV for input/output lines	Mains power quality should be that of a typical commercial or hospital environment.
Surge IEC 61000-4-5	± 1 kV differential mode ± 2 kV common mode	± 1 kV differential mode ± 2 kV common mode	Mains power quality should be that of a typical commercial or hospital environment.
Voltage dips, short interruptions and voltage variations on power supply input lines IEC 61000-4-11	< 5 % $U_T$ (>95 % dip in $U_T$ ) for 0,5 cycle  40 % $U_T$ (60 % dip in $U_T$ ) for 5 cycles  70 % $U_T$ (30 % dip in $U_T$ ) for 25 cycles  < 5 % $U_T$ (>95 % dip in $U_T$ ) for 5 sec	< 5 % $U_T$ (>95 % dip in $U_T$ ) for 0,5 cycle  40 % $U_T$ (60 % dip in $U_T$ ) for 5 cycles  70 % $U_T$ (30 % dip in $U_T$ ) for 25 cycles  < 5 % $U_T$ (>95 % dip in $U_T$ ) for 5 sec	Mains power quality should be that of a typical commercial or hospital environment. If the user of the OLYMPIA BARIATRIC bed requires continued operation during power mains interruptions, it is recommended that the OLYMPIA BARIATRIC bed be powered from an uninterruptible power supply or a battery.
Power frequency (50/60 Hz) magnetic field IEC 61000-4-8	3 A/m	3 A/m	Power frequency magnetic fields should be at levels characteristic of a typical location in a typical commercial or hospital environment.

NOTE  $U_T$  is the a. c. mains voltage prior to application of the test level.

## Guidance and manufacturer's declaration – electromagnetic immunity

The OLYMPIA BARIATRIC bed is intended for use in the electromagnetic environment specified below. The customer or the user of the OLYMPIA BARIATRIC bed should assure that it is used in such an environment.

Immunity test	IEC 60601 test level	Compliance level	Electromagnetic environment - guidance
Conducted RF IEC 61000-4-6	3 V	3 V	Portable and mobile RF communications equipment should be used no closer to any part of the OLYMPIA BARIATRIC bed, including cables, than the recommended separation distance calculated from the equation applicable to the frequency of the transmitter.  <b>Recommended separation distance</b> $d = \left[ \frac{3,5}{V_1} \right] \sqrt{P}$
Radiated RF IEC 61000-4-3	3 V/m  80 MHz to 2,5 GHz	3 V/m	$d = \left[ \frac{3,5}{E_1} \right] \sqrt{P} \quad 80 \text{ MHz to } 800 \text{ MHz}$ $d = \left[ \frac{7}{E_1} \right] \sqrt{P} \quad 800 \text{ MHz to } 2,5 \text{ GHz}$ <p>where <math>p</math> is the maximum output power rating of the transmitter in watts (W) according to the transmitter manufacturer and <math>d</math> is the recommended separation distance in metres (m).<sup>b</sup></p> <p>Field strengths from fixed RF transmitters, as determined by an electromagnetic site survey,<sup>a</sup> should be less than the compliance level in each frequency range.<sup>b</sup></p> <p>Interference may occur in the vicinity of equipment marked with the following symbol:</p> <div style="text-align: center;">  </div>

NOTE 1 At 80 MHz and 800 MHz, the higher frequency range applies.

NOTE 2 These guidelines may not apply in all situations. Electromagnetic propagation is affected by absorption and reflection from structures, objects and people.

<sup>a</sup> Field strengths from fixed transmitters, such as base stations for radio (cellular/cordless) telephones and land mobile radios, amateur radio, AM and FM radio broadcast and TV broadcast cannot be predicted theoretically with accuracy. To assess the electromagnetic environment due to fixed RF transmitters, an electromagnetic site survey should be considered. If the measured field strength in the location in which the OLYMPIA BARIATRIC bed is used exceeds the applicable RF compliance level above, the OLYMPIA BARIATRIC bed should be observed to verify normal operation. If abnormal performance is observed, additional measures may be necessary, such as reorienting or relocating the OLYMPIA BARIATRIC bed.

<sup>b</sup> Over the frequency range 150 kHz to 80 MHz, field strengths should be less than 3 V/m.



## Recommended separation distances between portable and mobile RF communications equipment and the OLYMPIA BARIATRIC bed

The OLYMPIA BARIATRIC bed is intended for use in an electromagnetic environment in which radiated RF disturbances are controlled. The customer or the user of the OLYMPIA BARIATRIC bed can help prevent electromagnetic interference by maintaining a minimum distance between portable and mobile RF communications equipment (transmitters) and the OLYMPIA BARIATRIC bed as recommended below, according to the maximum output power of the communications equipment

Rated maximum output of transmitter W	Separation distance according to frequency of transmitter m		
	150 kHz to 80 MHz $d = [\frac{3,5}{V_1}] \sqrt{P}$	80 MHz to 800 MHz $d = [\frac{3,5}{E_1}] \sqrt{P}$	800 MHz to 2,5 GHz $d = [\frac{7}{E_1}] \sqrt{P}$
0,01	0,12	0,12	0,23
0,1	0,37	0,37	0,74
1	1,17	1,17	2,33
10	3,69	3,69	7,38
100	11,67	11,67	23,33

***For transmitters rated at a maximum output power not listed above the recommended separation distance  $d$  in metres (m) can be estimated using the equation applicable to the frequency of the transmitter, where  $P$  is the maximum output power rating of the transmitter in watts (W) according to the transmitter manufacturer.***

NOTE 1 At 80 MHz and 800 MHz, the separation distance for the higher frequency range applies.

NOTE 2 These guidelines may not apply in all situations. Electromagnetic propagation is affected by absorption and reflection from structures, objects and people.

**APPENDIX 4: TRAINING CERTIFICATE**

# Training Certificate

**Customer & instructor specifications**

Customer:	Company + Contact information.....	Training followed by.....
	.....	.....
Instructor:	Company + Contact information.....	Training given by.....
	.....	.....

**Product specifications**

Product name + description	Article number:	.....
.....	Serial number:	.....
.....	Sales order number:	.....
.....	Delivery date:	.....

**Certificate of training**

I hereby confirm that the user has received a training to become familiar with the use of this product.		
Remarks:		
.....		
.....		
.....		
.....		
Date:	Name + customer signature + stamp	Name + instructor signature + stamp
.....	.....	.....



HAEVOET NV | L. BEKAERTSTRAAT 8, 8770 INGELMUNSTER, BELGIUM | T +32 (0) 51 48 66 95 | F +32 (0) 51 48 73 19 | INFO@HAEVOET.BE | WWW.HAEVOET.BE

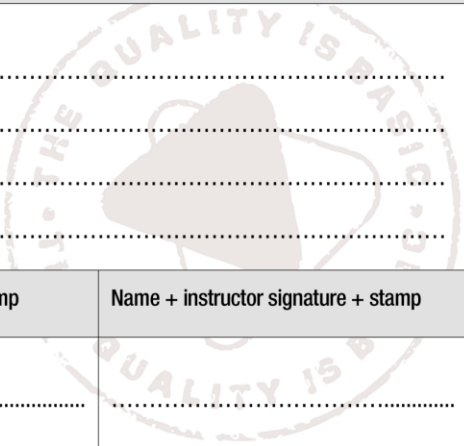

Written by:

Haelvoet NV  
Leon Bekaertstraat 8  
8770 Ingelmunster  
Belgium

Tel. +32 51 48 66 95  
Fax. +32 51 48 73 19

[info@haelvoet.com](mailto:info@haelvoet.com)  
[www.haelvoet.com](http://www.haelvoet.com)



All rights reserved. Nothing from these operating instructions and this technical manual may be reproduced without the prior written consent of Haelvoet NV.